

EPFL

Cours Electrotechnique I :

2. Conventions et Symboles :

→ Concepts

Ex : Courant : i , I , \hat{I} , \tilde{i} , \bar{I} , \underline{I}

unité : [A]

Relations : $U = R \cdot I$
 $u = R \cdot i$

choix : Convention Noter

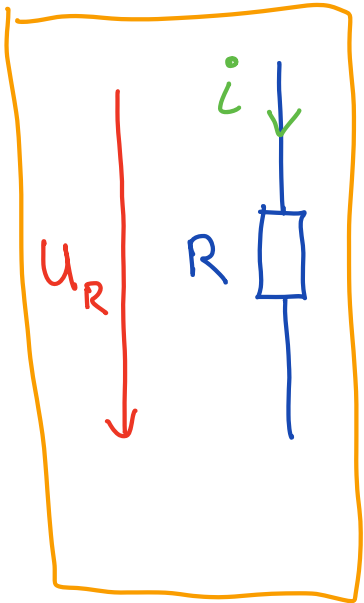

International

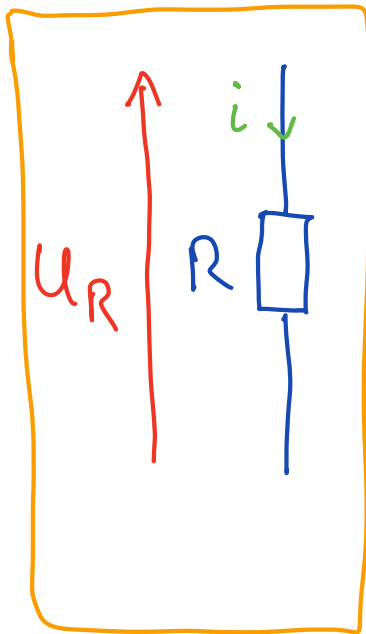

France

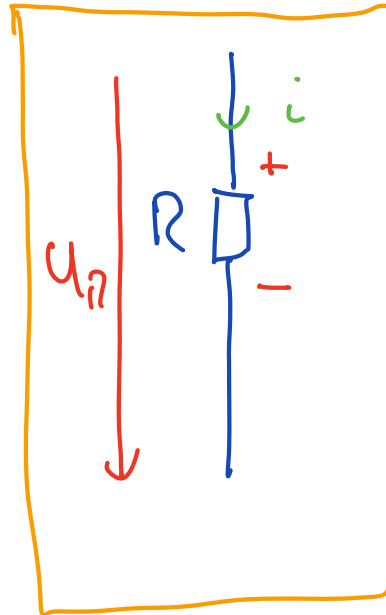

USA, B

$$P_R = R \cdot I^2 = UI = \text{positive}$$

2.2 Représentation graphique :

Conducteur parfait : 

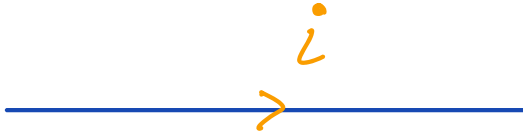
Conducteur avec un courant : 

Élément :

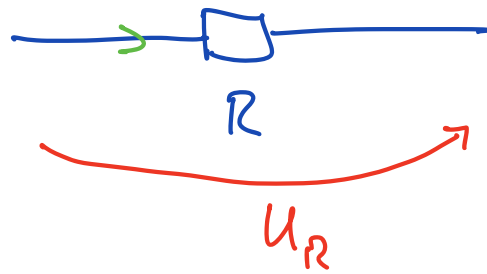

Interrupteur :

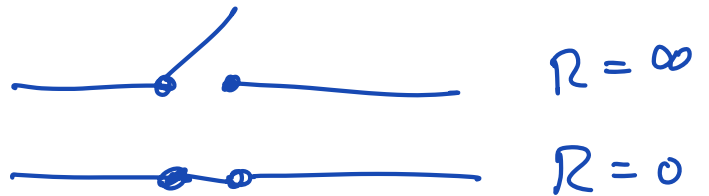

3. Lois fondamentales :

Champ électrique :

Différence de potentiel électrique

$$V_A - V_B = \int_a^b E \, dl = U_{ab}$$

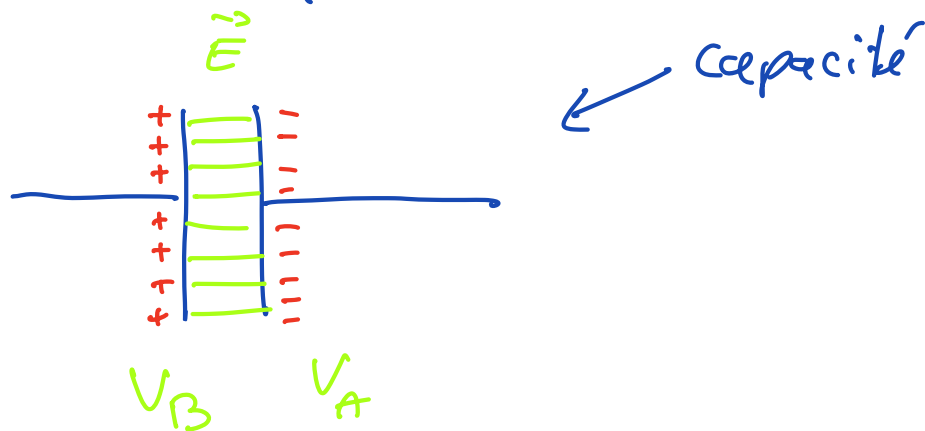

3.2.19 La Capacité :

Définition : Charge électrique : Q

capacité : $C = \frac{Q}{U_{ab}}$ $[F]$
(Farad)

Symbole : 

3.3 Courant électrique :

$$i = \frac{dQ}{dt} \quad [A]$$

$$j = \text{Densité de courant} \quad [A/m^2]$$

3.34 Pertes Joule

$$P = R \cdot I^2 \quad [W]$$

$$P = \int_V j \, dV_{cu}$$

3.3.6 Résistance :

b



$$R_{ab} = \int_a^l \rho \frac{dl}{S}$$

↑
résistivité' [Ωm]

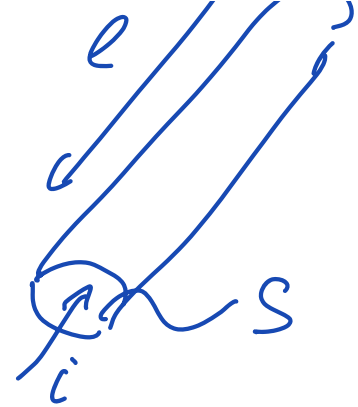

Si on a un milieu homogène et
S est cste :

$$R = \frac{\rho \cdot l}{S} \quad [\Omega]$$

3.3.8 Loi d'Ohm :

$$U_{ab} = R_{ab} \cdot I$$

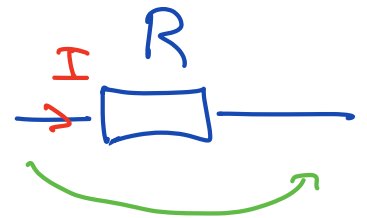

(Tension et le courant sont constants) U_{ab}

$$u_{ab} = R_{ab} \cdot i$$

(Tension et le courant sont variables)

3.3.11 Lois de Kirchhoff :

Noeud : Pt de convergence d'au moins 3 conducteurs

$$\underline{\sum i_j = 0}$$

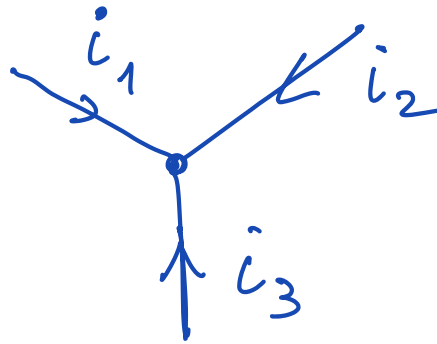

$$i_1 + i_2 + i_3 = 0$$

Noeud généralisé :

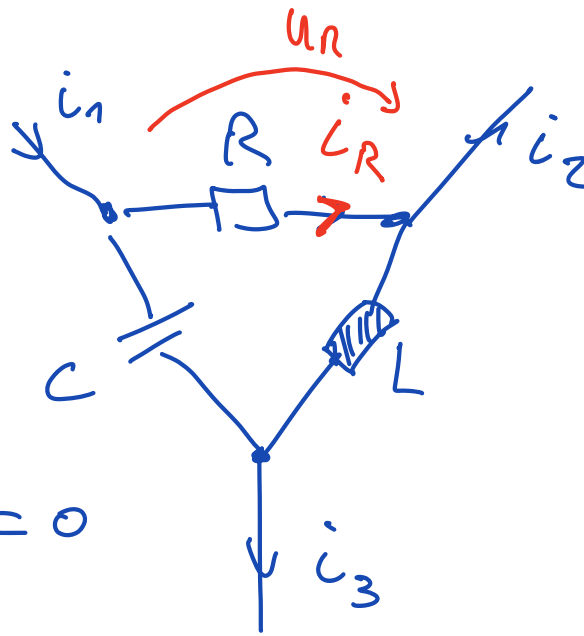

$$i_1 - i_2 - i_3 = 0$$

Maille : Ensemble de branche partent d'un noeud pour y revenir

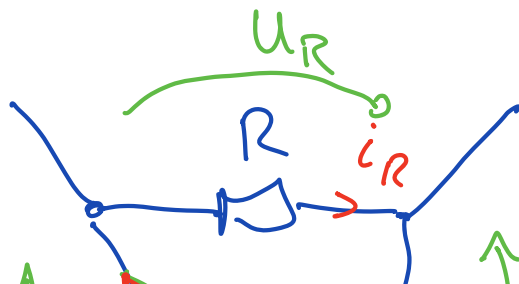

$$\underline{\sum U_j = 0}$$



$$U_R - U_L + U_C = 0$$

3.4 Inductance :

$$u = L \frac{di}{dt}$$

$$\begin{aligned} \vec{\text{Rot}} \vec{H} &= \vec{j} \\ \vec{\text{Rot}} \vec{E} &= -\frac{\partial \vec{B}}{\partial t} \end{aligned}$$

Crée une tension en fonction de la variation du courant

3.5 La Capacité

$$C = \frac{Q}{U_{ab}}$$

$$Q = \int i dt$$

$$U_{ab} = \frac{1}{C} \int i dt$$

4. Eléments de circuit :

4.1 Définition : Dipôle : circuit qui possède 2 bornes

4.2 Sources de tension et courant :

a) Source de tension idéale :

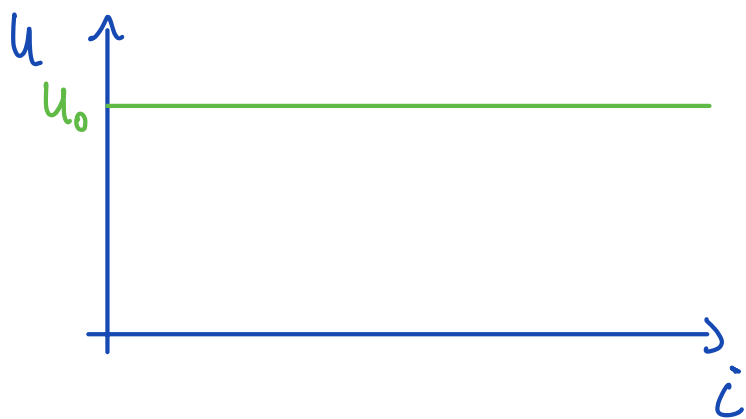
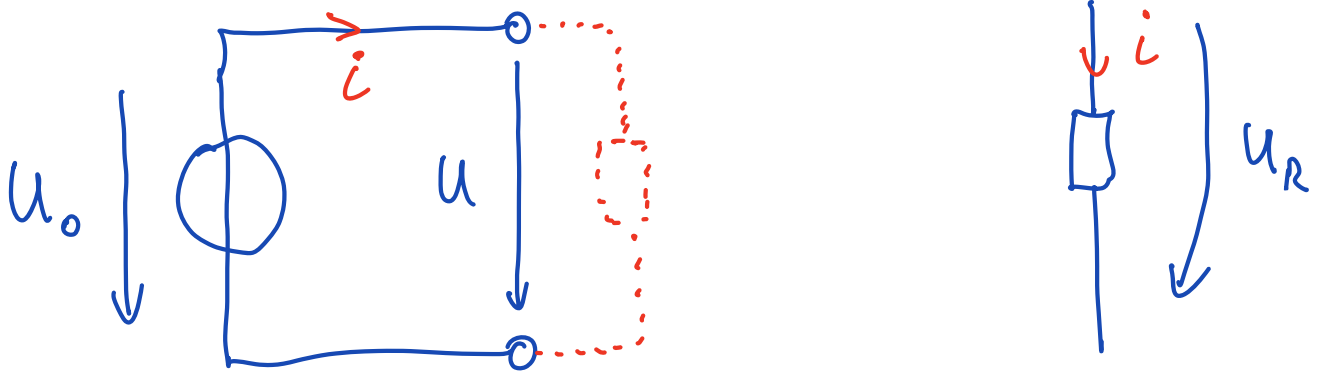

c'est un élément virtuel et inexistant dans la nature

b) Source de courant idéal :

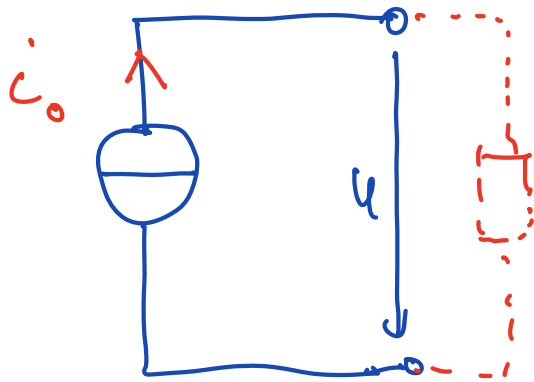

élément idéal
inexistent dans
la nature

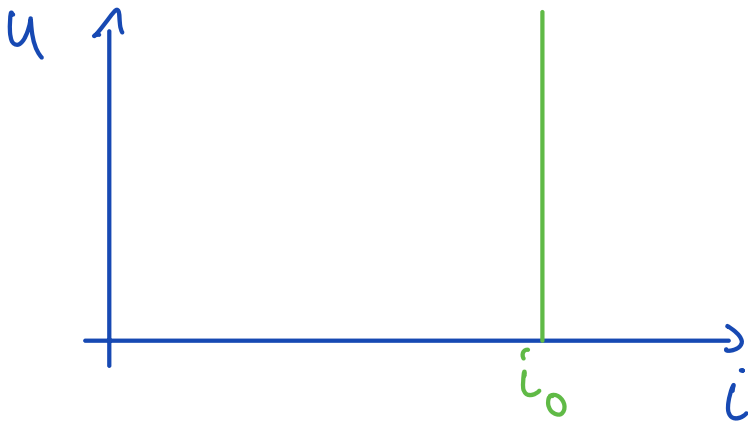

4.2.5 Source de tension réelle :

Définition :

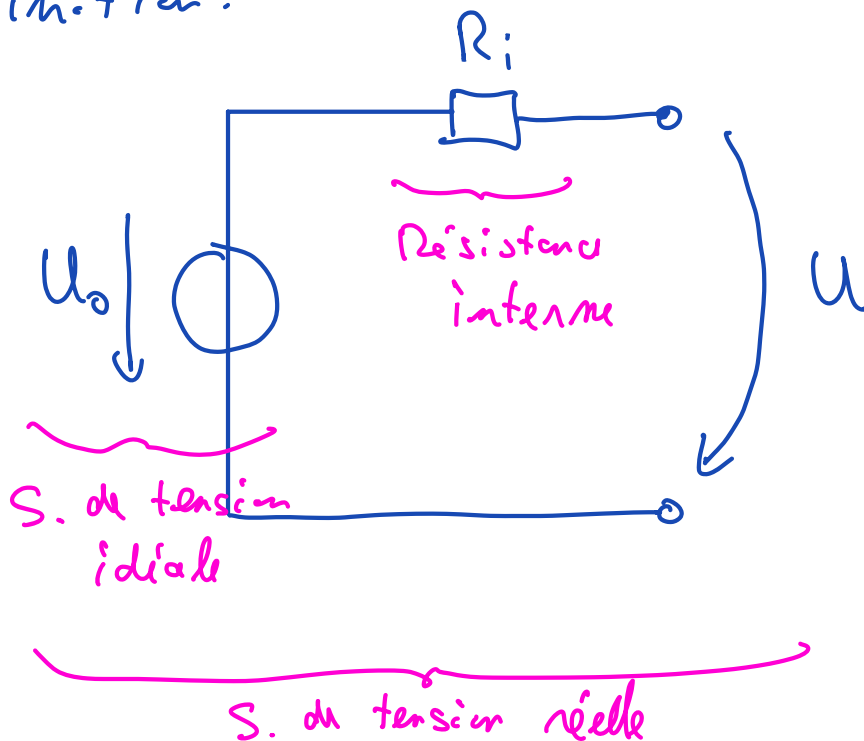

U_0 : Tension à vide (pas de charge connectée)

R_i : Résistance interne

U : Tension de la source réelle

$$\sum U = 0$$

$$\rightarrow -U_0 + R_i \cdot I + U = 0$$

$$\underline{\underline{U = U_0 - R_i I}}$$

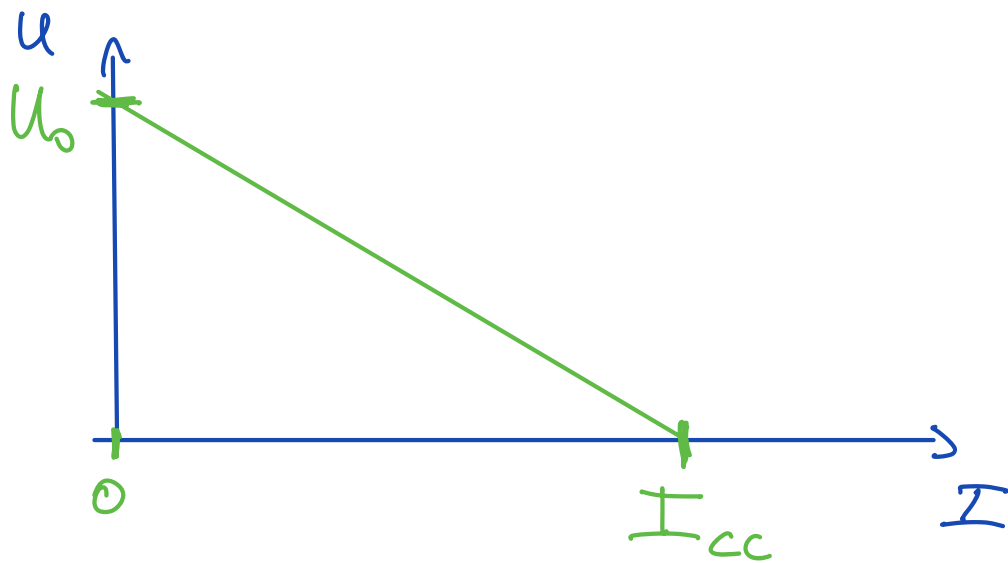

I_{cc} = courant - court circuit

Si on est en court-circuit :

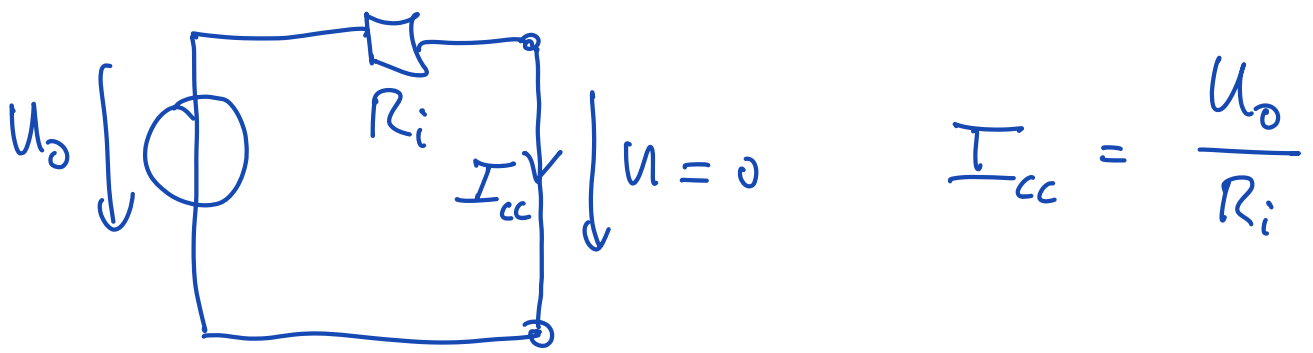

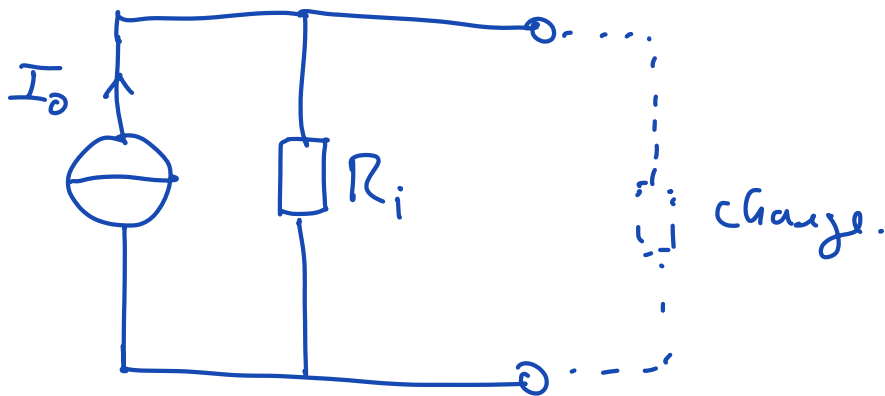

4.2.6 Source de courant réel =



4.3 Éléments de base :

Résistance : 

Inductance : 
 ()

Capacité : 
 C

Rappel : $U_L = L \frac{di}{dt}$ en continu $U_L = 0$

4.4 Schéma électrique :

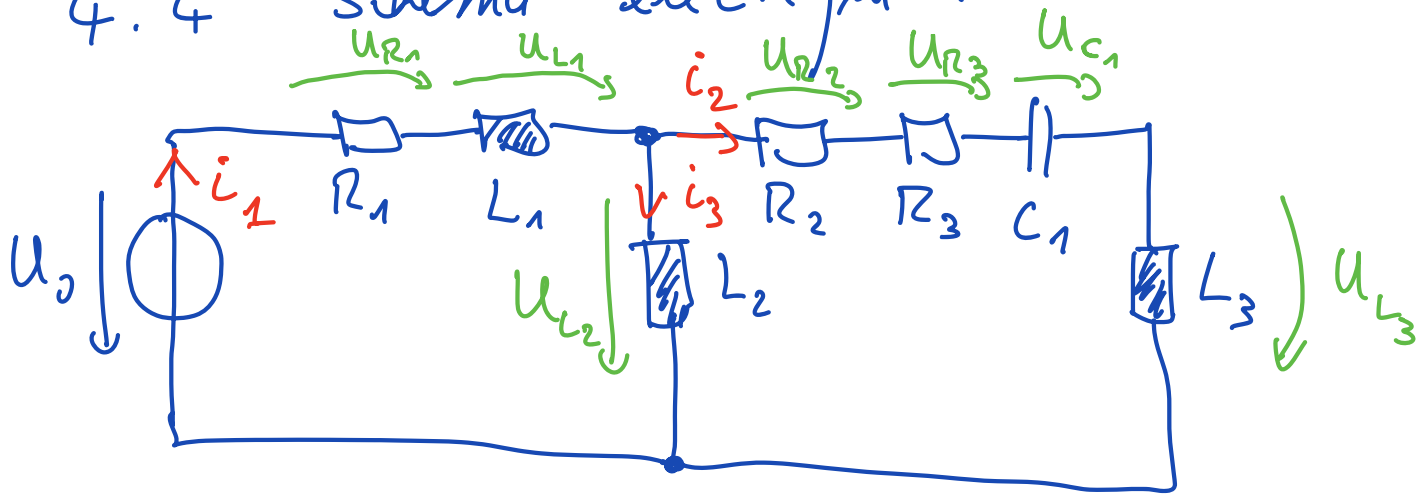

5. Combinaison simple d'éléments linéaires

5.2 Mise en série :

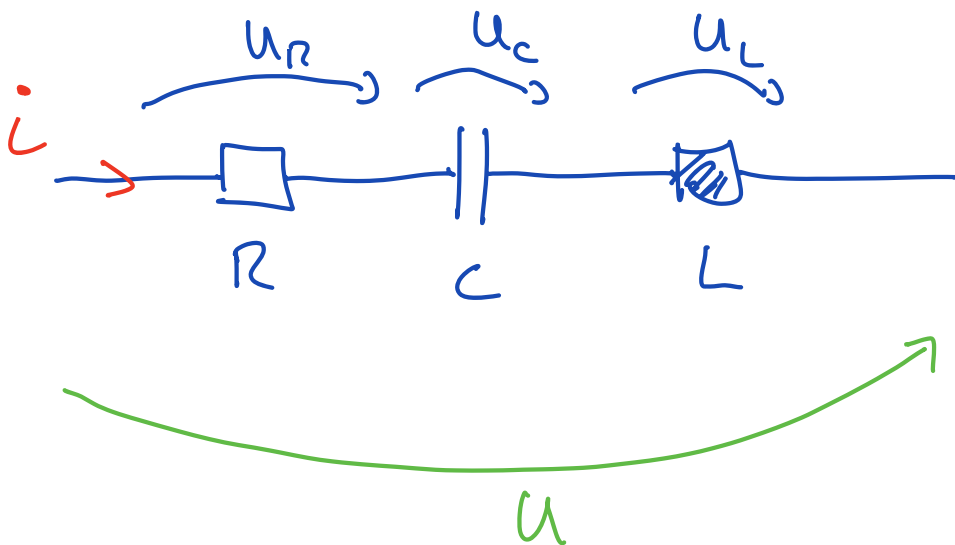

Série : parcouru par le même courant

$$i_R = i_C = i_L$$

$$u = u_R + u_C + u_L$$

5.2.2 Mise en série de R :

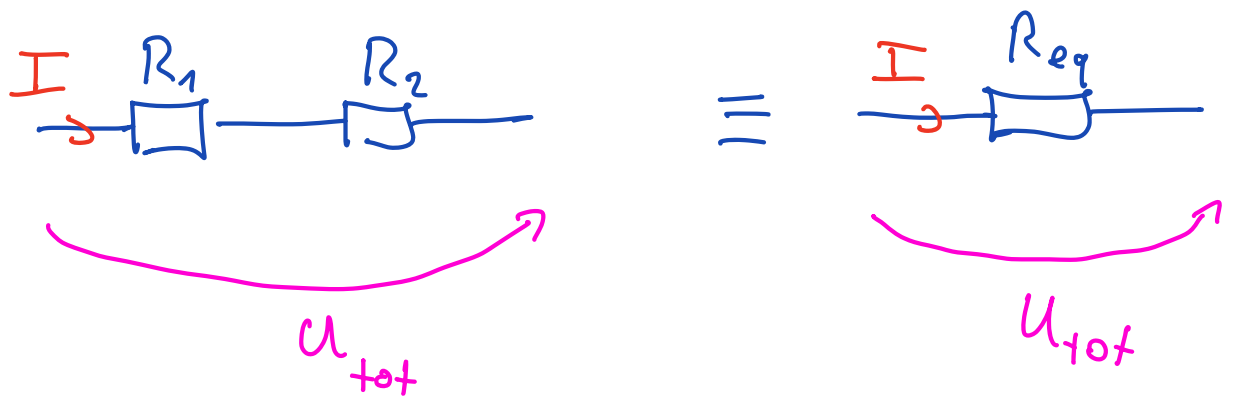

$$U_{\text{tot}} = U_{R_1} + U_{R_2}$$

$$U_{\text{tot}} = U_{R_{\text{eq}}}$$

$$= R_1 \cdot I + R_2 \cdot I$$

$$U_{\text{tot}} = (R_1 + R_2) \cdot I$$

$$\underbrace{\hspace{10em}}_{R_{\text{eq}}}$$

Série $R_{\text{eq}} = \sum_{k=1}^m R_k$ ($m = \text{nb de } R \text{ en série}$)

5.2.3 Mise en série des C

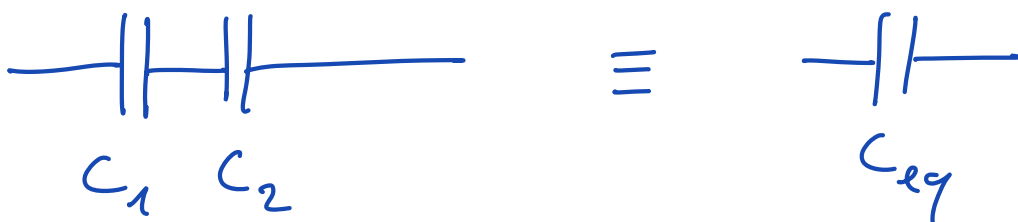

Série $C_{\text{eq}} = \frac{1}{\sum_{k=1}^m \frac{1}{C_k}}$ ($m = \text{nb de } C$)

$$\sum_{k=1}^m C_k$$

5.2.6 Mise en série des L

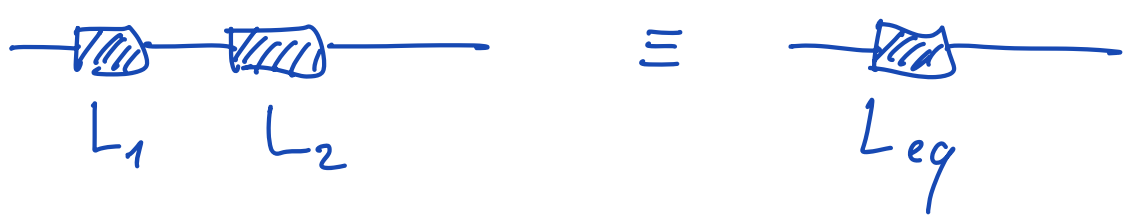

Série :
$$L_{eq} = \sum_{k=1}^m L_k \quad (m = nb \text{ de } L)$$

5.2.7 Mise en série des source de tension :

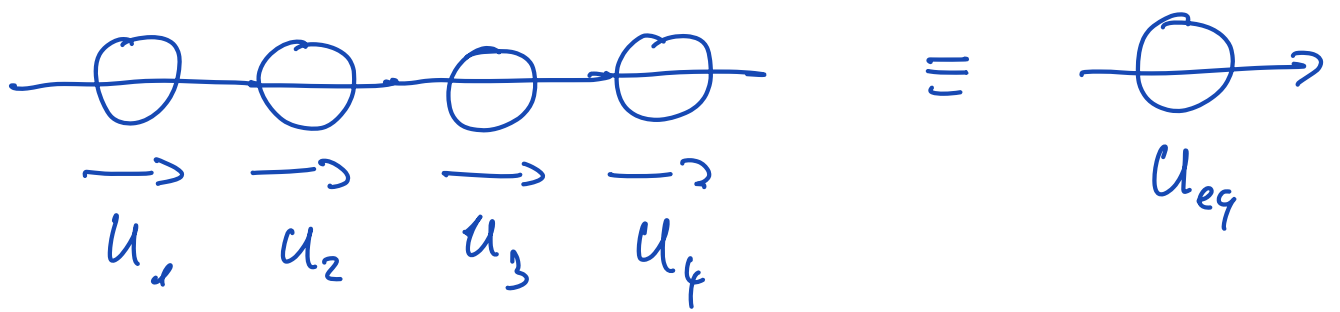

Série
$$U_{eq} = \sum_{k=1}^m U_k \quad (m \text{ sources})$$

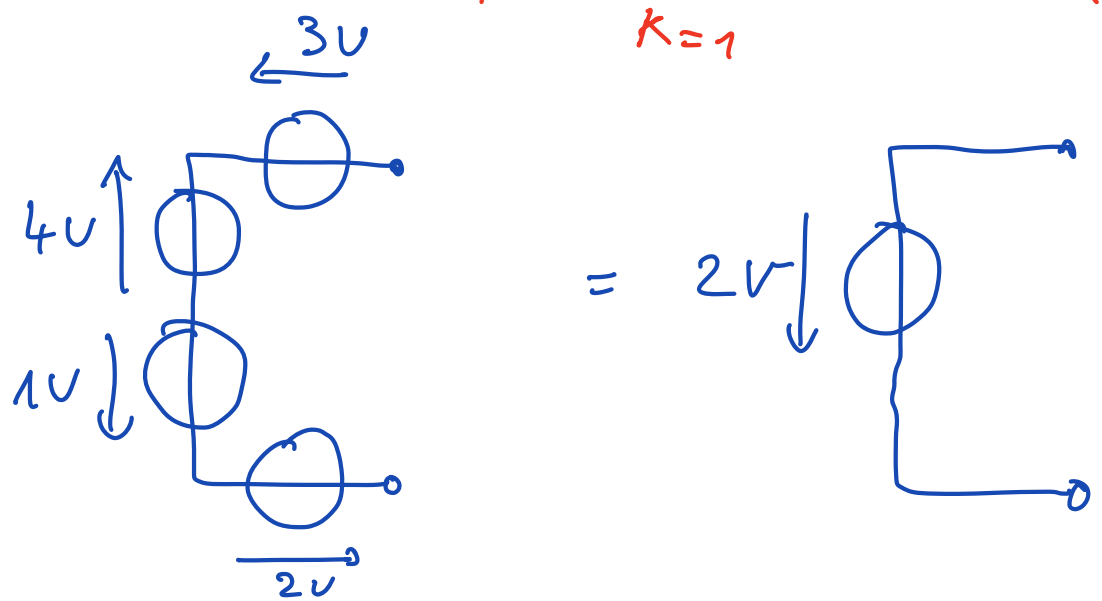

5.2.9 Mise en série des sources de courant

\Rightarrow Impossible sauf si toutes les sources ont la même valeur!

5.3 Mise en parallèle :

Définition : Toutes les bornes des éléments sont au même potentiel

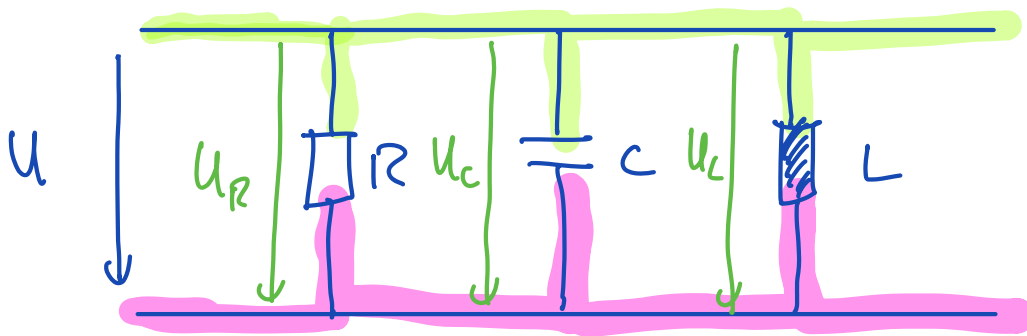

Exemple :

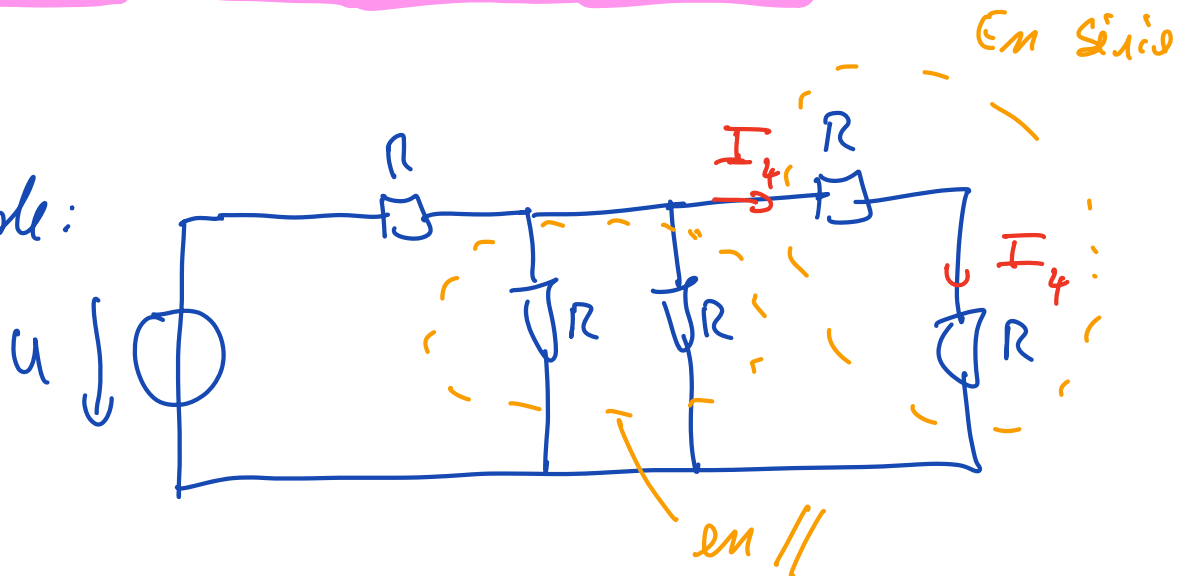

5.3.2 Mise en // des R :



$$R_{eq} = \frac{1}{\sum_{k=1}^m \frac{1}{R_k}} \quad m = \text{nb de } R$$

$$\frac{1}{R_{eq}} = \frac{1}{R_1} + \frac{1}{R_2} \Rightarrow \underline{\underline{R_{eq} = \frac{R_1 R_2}{R_1 + R_2}}}$$

5.3.5 Mise en // des C :

$$C_{eq} = \sum_{k=1}^m C_k \quad m = \text{nb de } C$$

5.3.6 Mise en // des L :

$$L_{eq} = \frac{1}{\sum_{k=1}^m \frac{1}{L_k}} \quad m = \text{nb de } L$$

5.3.7 Mise en // des sources de courant.

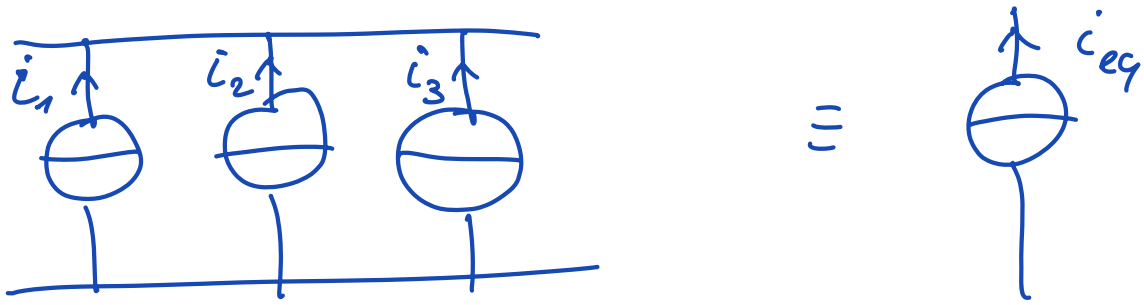

$$i_{\text{tot}} = i_{eq} = \sum_{k=1}^m i_k$$

Mise en // des sources de tensions est impossible !
 Sauf si toutes les tensions ont même valeur !

5.4 Circuits Combinés :

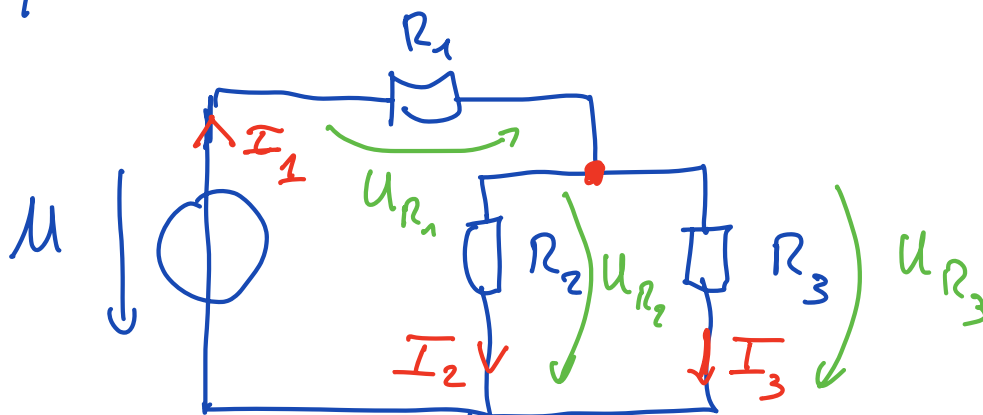

$$I_1 = I_2 + I_3$$

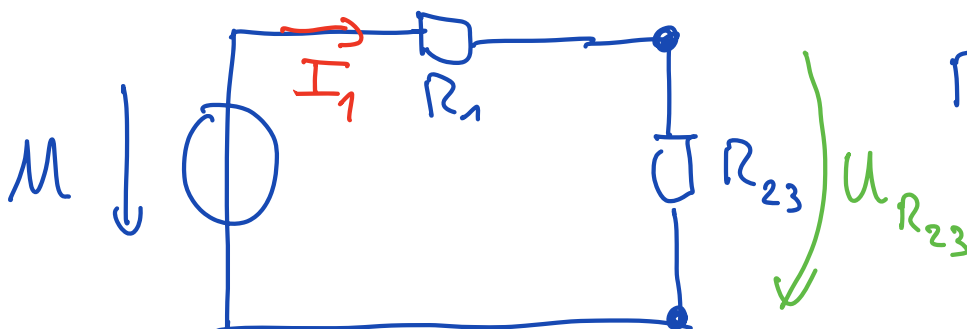

$$R_{23} = \frac{R_2 \cdot R_3}{R_2 + R_3}$$

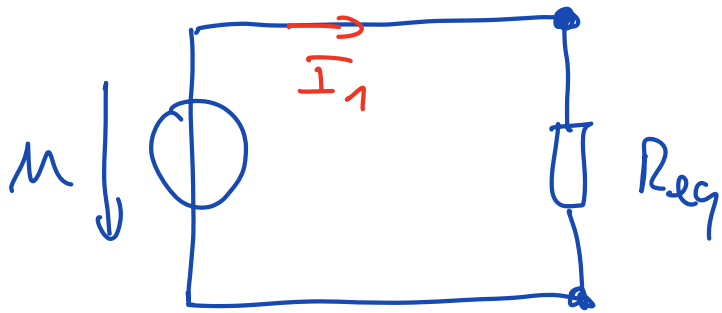

$$R_{eq} = R_1 + R_{23}$$

$$U = R_{eq} \cdot I_1 \quad \rightarrow \quad I_1 = \frac{U}{R_{eq}}$$

$$U_{R_1} = U_{R_3} = U_{R_{23}}$$

$$U_{R_{23}} = R_{23} \cdot I_1 = U_{R_2}$$

$$I_2 = \frac{U_{R_2}}{R_2}$$

5.4.3 Example :

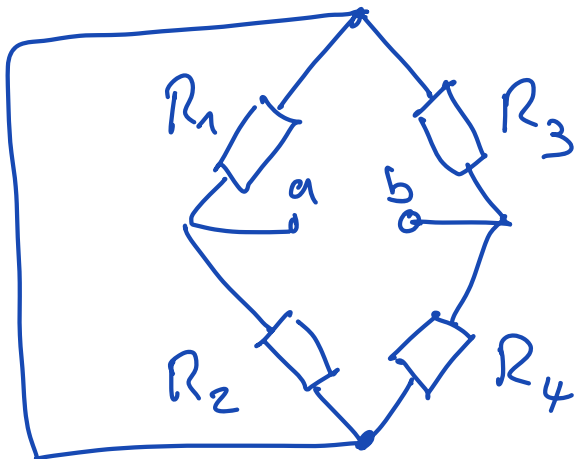

≡

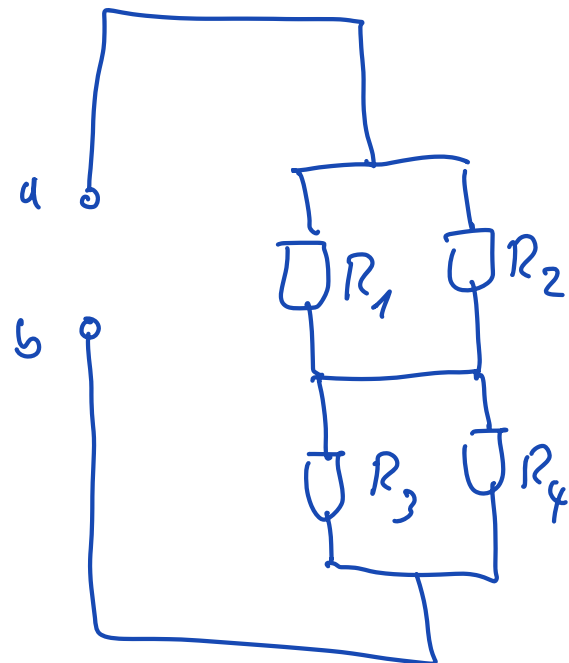

5.5.1 División de tensión:

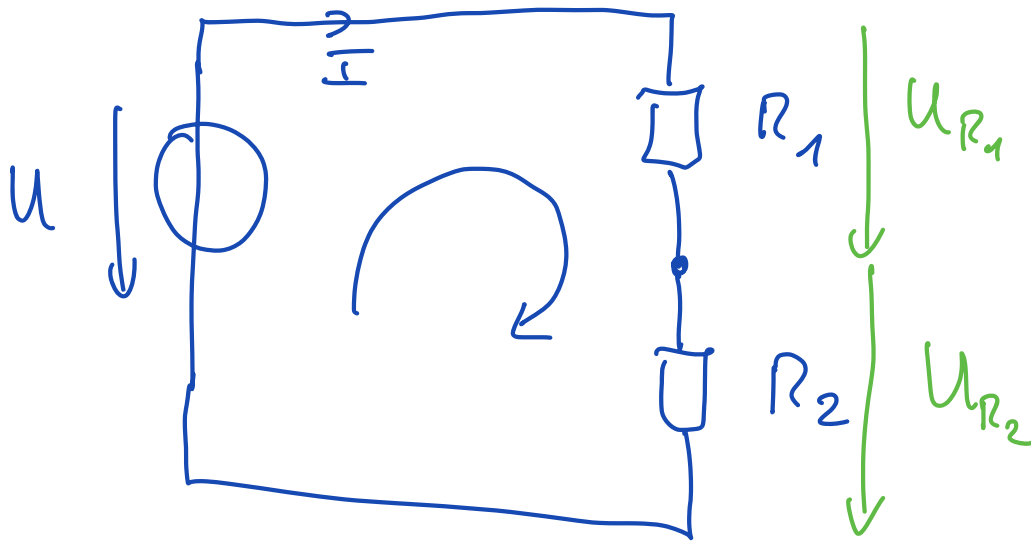

$$-U + U_{R_1} + U_{R_2} = 0$$

$$U = U_{R_1} + U_{R_2}$$

$$U = R_1 \cdot I + R_2 \cdot I = (R_1 + R_2) I$$

$$I = \frac{U}{R_1 + R_2}$$

$$U_{R_2} = R_2 \cdot I = U \cdot \frac{R_2}{R_1 + R_2}$$

$$U_{R_1} = R_1 \cdot I = U \cdot \frac{R_1}{R_1 + R_2}$$

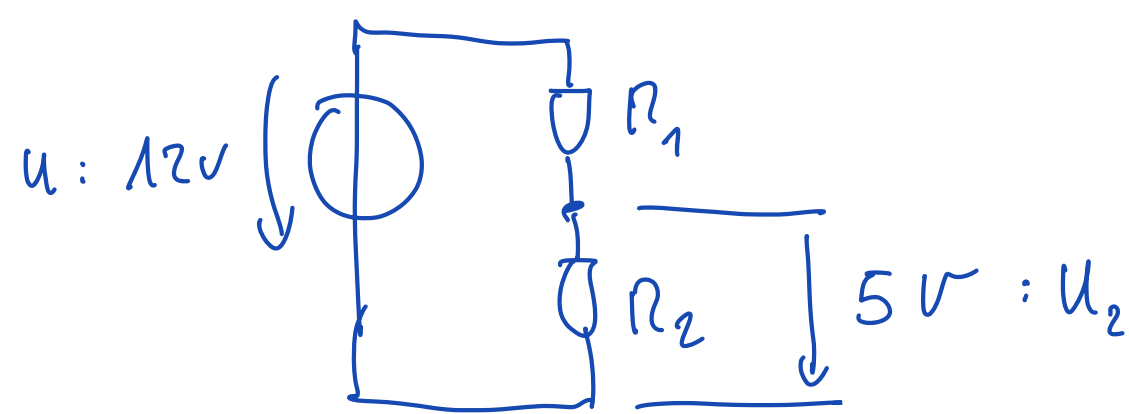

$$U_2 = \frac{R_2}{R_1 + R_2} \cdot U$$

$$5 = \frac{R_2}{R_1 + R_2} \cdot 12 \quad \Rightarrow \quad 5R_1 = 7R_2$$

$$R_1 = 100 \text{ k}\Omega$$

$$R_2 = 71,5 \text{ k}\Omega$$

5.5.4 Diviseur de courant:

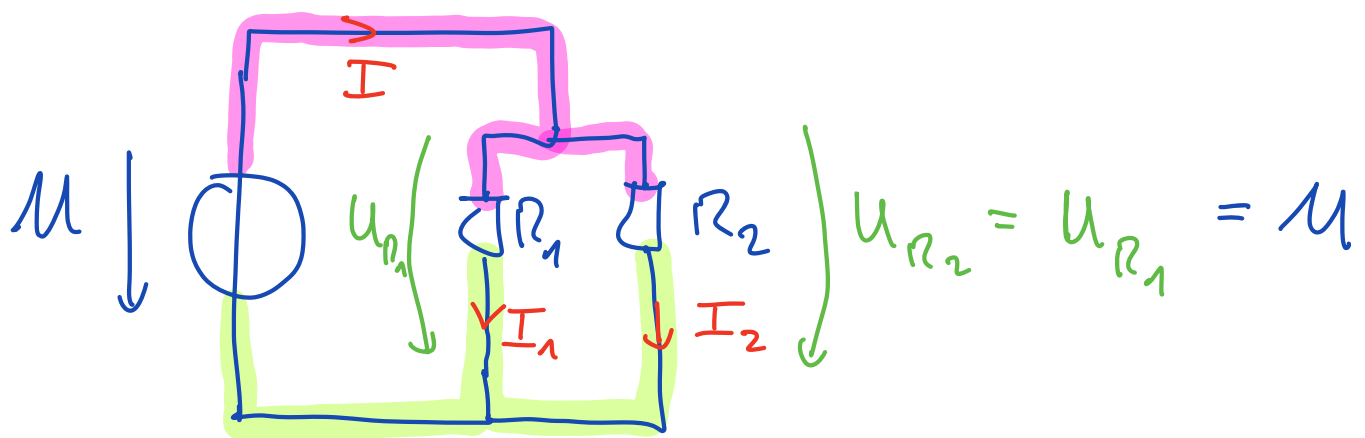

$$I = \frac{U}{R_{eq}} \quad R_{eq} = \frac{R_1 \cdot R_2}{R_1 + R_2}$$

$$U = U_2 = \frac{R_1 \cdot R_2}{R_1 + R_2} \cdot I = R_2 \cdot I_2$$

$$I_2 = \frac{R_1}{R_1 + R_2} \cdot I$$
$$I_1 = \frac{R_2}{R_1 + R_2} \cdot I$$

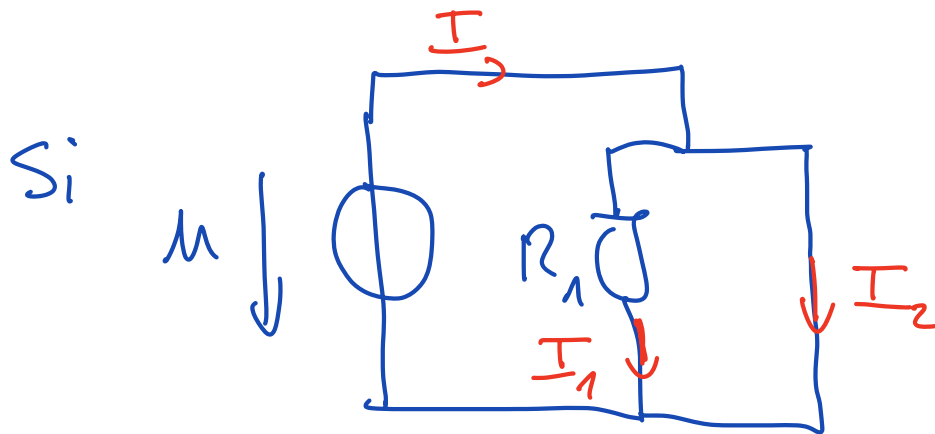

5.6 Méthodes de Résolution :

- Redessiner le schéma
- Définir toutes les grandeurs (U, I, i)
- " les sens
- Réduire le schéma
- Analyser

5.6.2 Source de tension réelle :

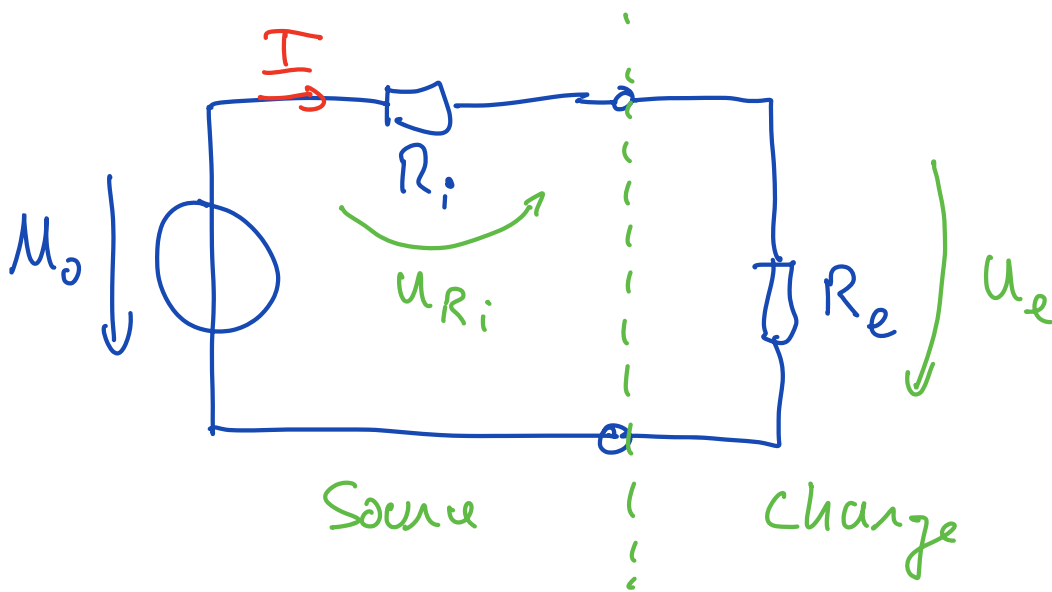

$$U_e = U_0 - U_{R_i} = U_0 - R_i \cdot I \quad |||$$

$$U_e = \quad \quad \quad = R_e \cdot I \quad |||$$

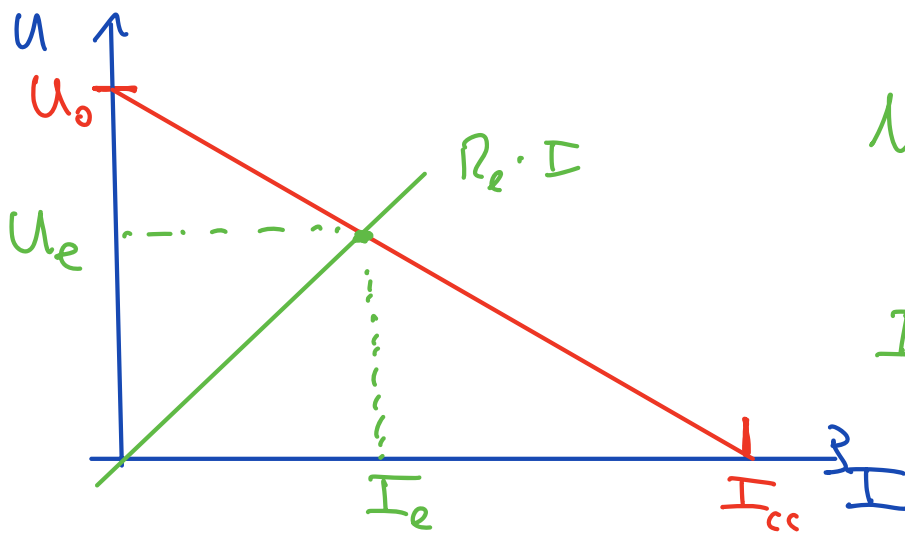

$$U_e = U_0 \cdot \frac{R_e}{R_e + R_i}$$

$$I_e = \frac{U_0}{R_i + R_e}$$

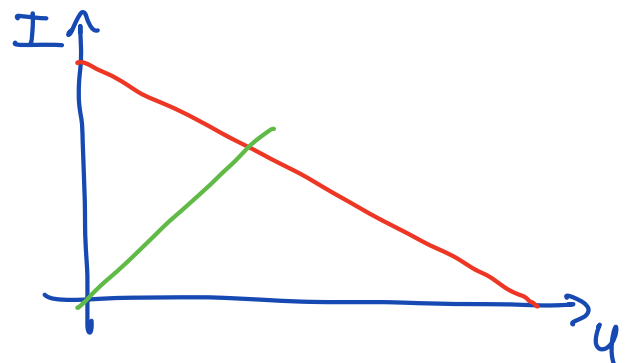
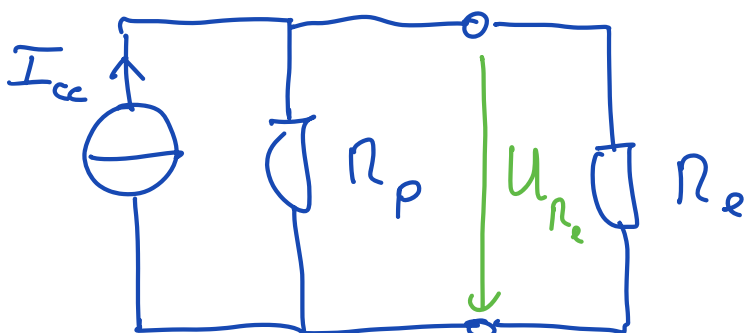

5.6.3 Equivalence des sources de tension et courant

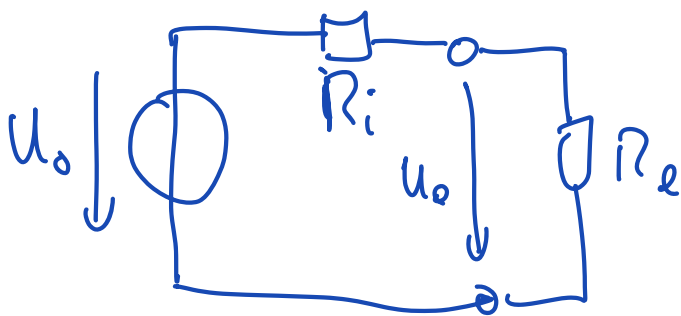
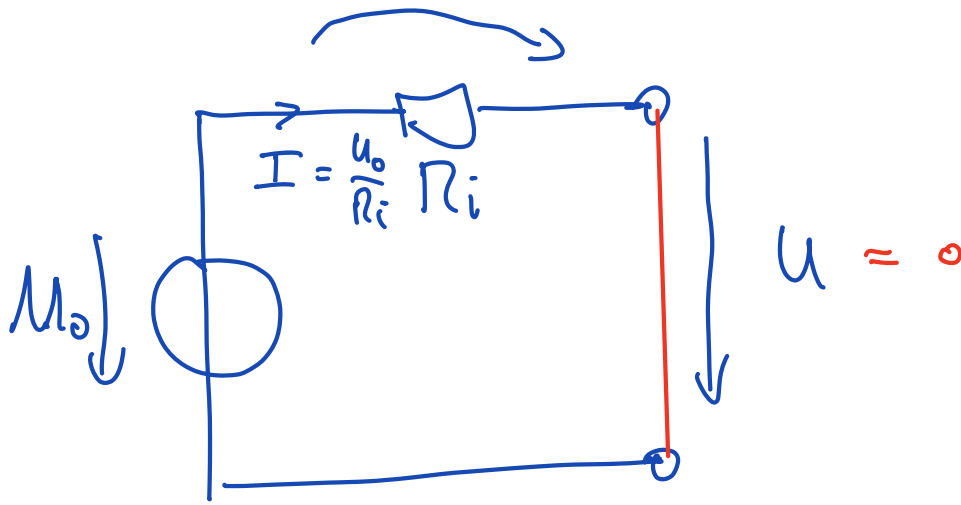

court-circuit

$$R_e = 0$$

$$U_{e_{cc}} = 0$$

$$I_{cc} = \frac{U_0}{R_i}$$

circuit ouvert
(pas de R_e)

$$U_{e_0} = U_0$$

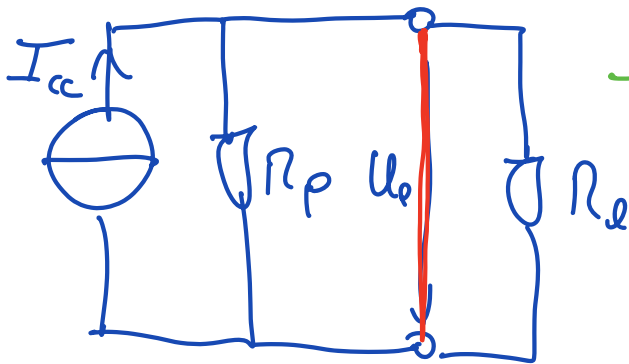

$$I_{e_{cc}} = I_{cc}$$

$$U_{e_{cc}} = 0$$

$$U_{e_0} = R_p I_{cc}$$

On pose $U_{e_0} = R_p I_{cc} = U_0$

$$I_{cc} = \frac{U_0}{R_i} = I_{e_{cc}}$$

$$R_p = \frac{U_o}{I_{cc}} = \frac{U_o}{U_o/R_i} = R_i$$

En résumé :

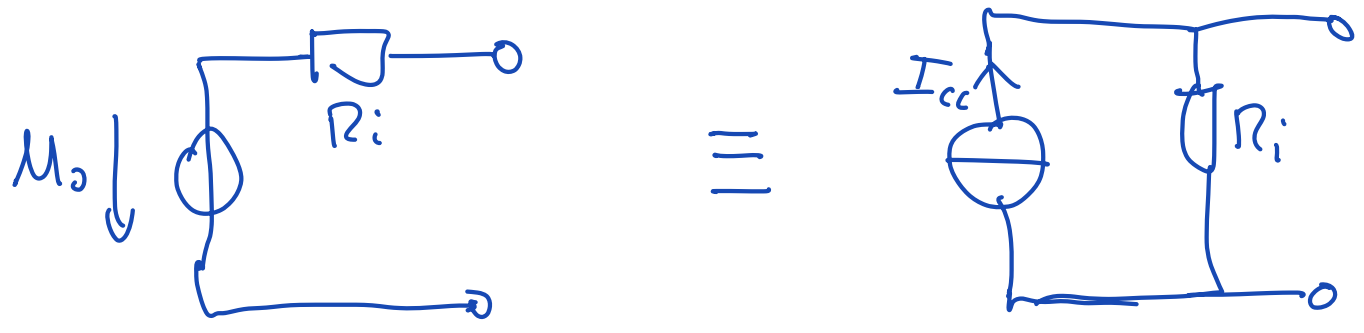

5.7 THÉORÈMES DE THÉVENIN ET DE NORTON

5.8 PRINCIPE DE SUPERPOSITION

5.9 TRANSFORMATION π -T

5.11 PUISSANCE MAXIMALE ET ADAPTATION

BILAN

Électrotechnique I

Yves PERRIARD & Yoan CIVET

Laboratoire d'Actionneurs Intégrés

5.7 THÉORÈMES DE THÉVENIN ET DE NORTON

CIRCUITS ÉQUIVALENTS

Électrotechnique I

Yves PERRIARD & Yoan CIVET

Laboratoire d'Actionneurs Intégrés

Définitions

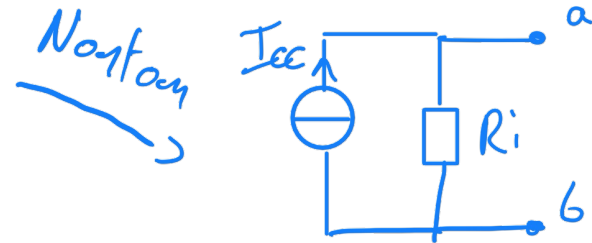
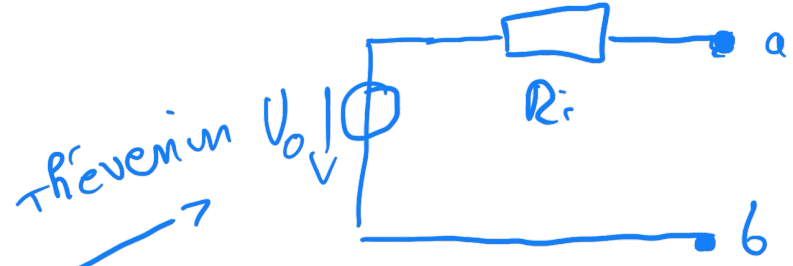
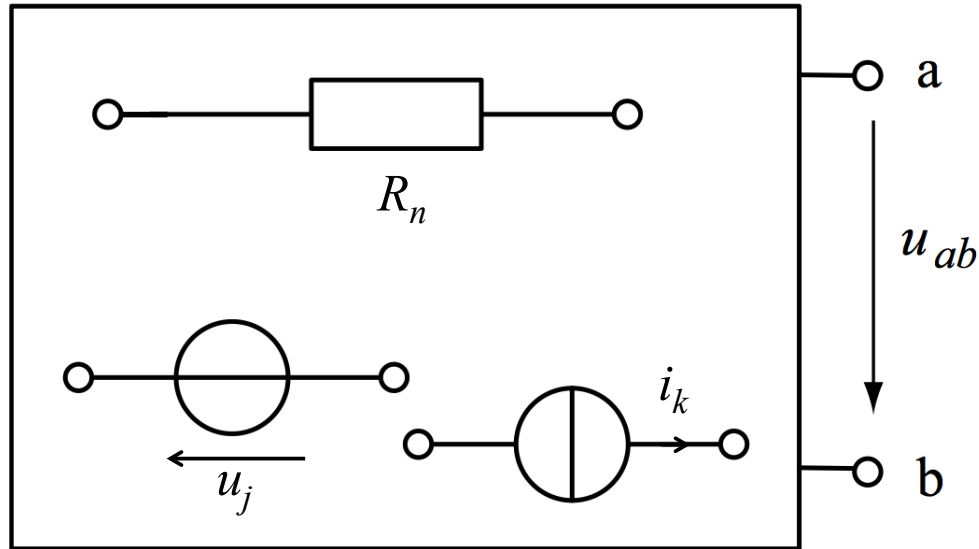

Tension à vide – Courant de court-circuit – Résistance interne

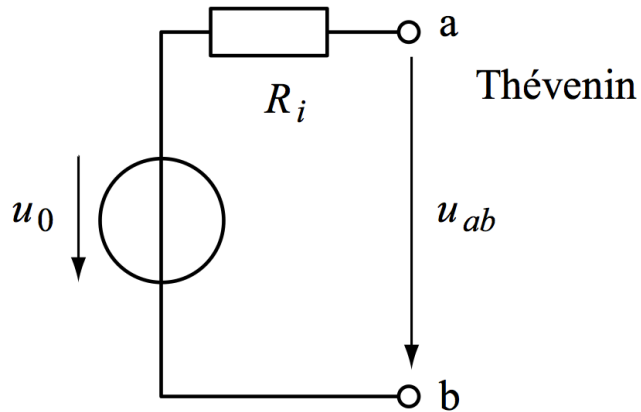

* $U_0 =$ tension à vide

$$U_0 = U_{ob} \Big|_{\substack{\text{à vide} \\ I_{ab} = 0}}$$

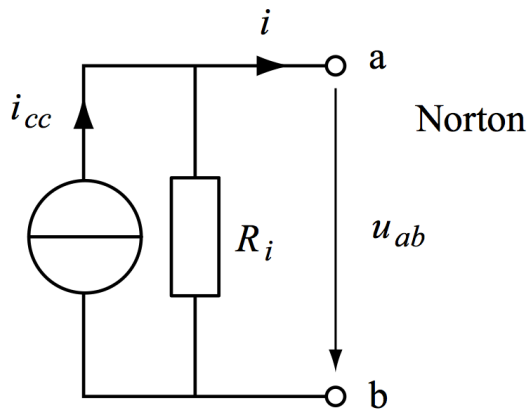

* $I_{cc} = I_{ab} \Big|_{\substack{U_{ob} = 0 \\ \text{en court-circuit.}}}$

$$* R_i = \frac{U_0}{I_{cc}} = R_{ab} \Big|_{\substack{U_j = 0 \\ i_k = 0}}$$

Annuler
les sources

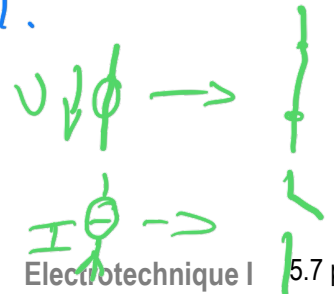

5.7 THÉORÈMES DE THÉVENIN ET DE NORTON

Exemple

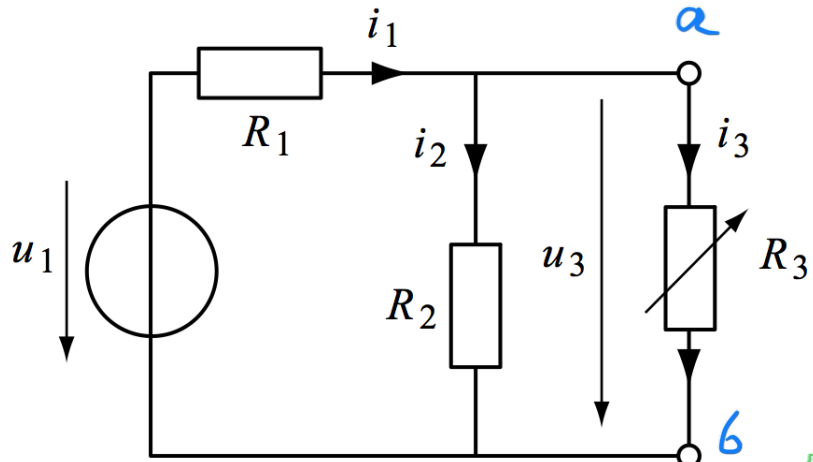

source

charge

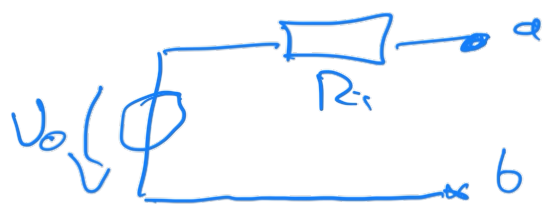

* Tension à vide

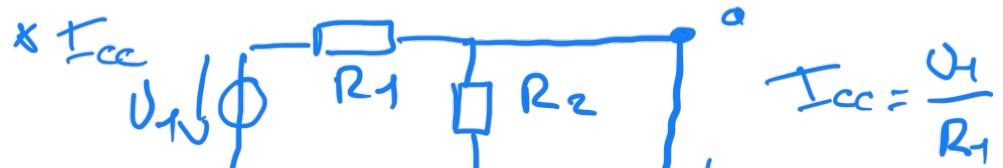
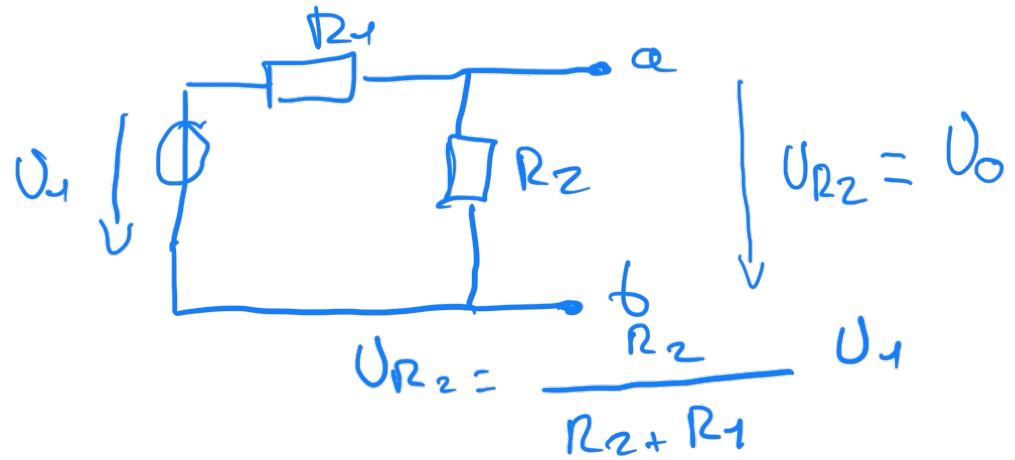

* $R_i = \frac{U_0}{I_{cc}} = \frac{R_1 R_2}{R_1 + R_2}$

5.7 THÉORÈMES DE THÉVENIN ET DE NORTON

Autre possibilité

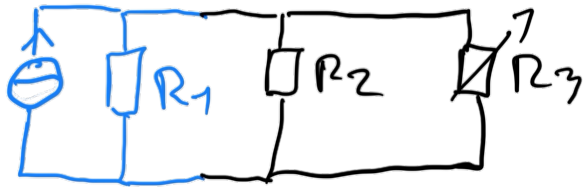
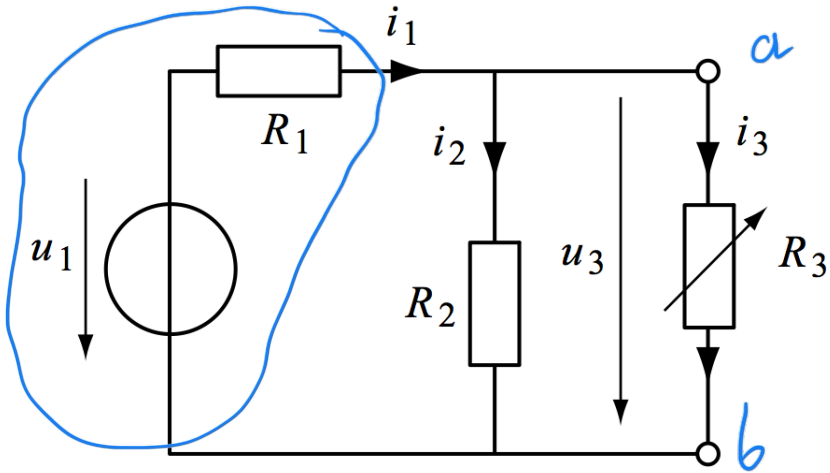

$$I_{cc} = \frac{U_1}{R_1}$$

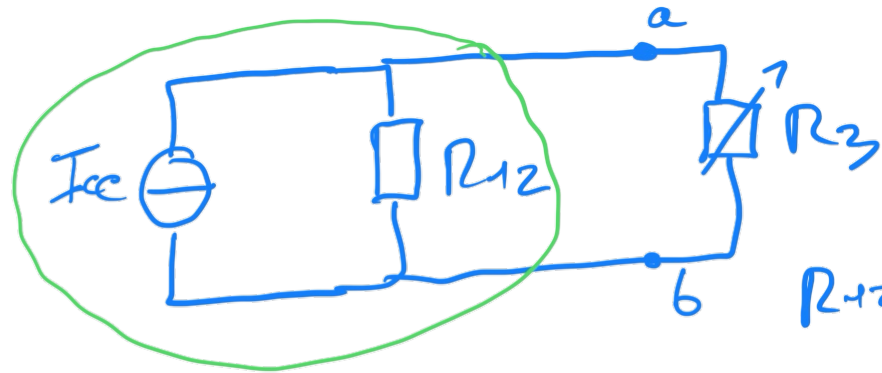

$$R_{12} = \frac{R_1 R_2}{R_1 + R_2}$$

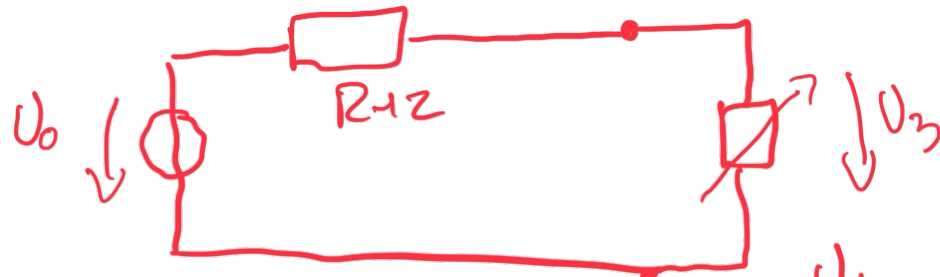

$$U_0 = R_{12} I_{cc} = \frac{R_1 R_2}{R_1 + R_2} \frac{U_1}{R_1} = \frac{R_2}{R_1 + R_2} U_1$$

Autre exemple

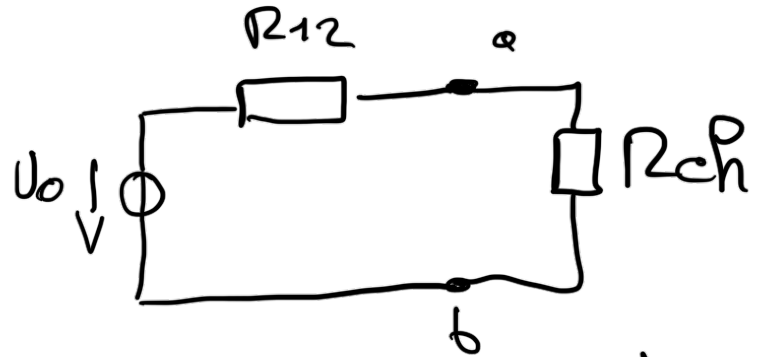
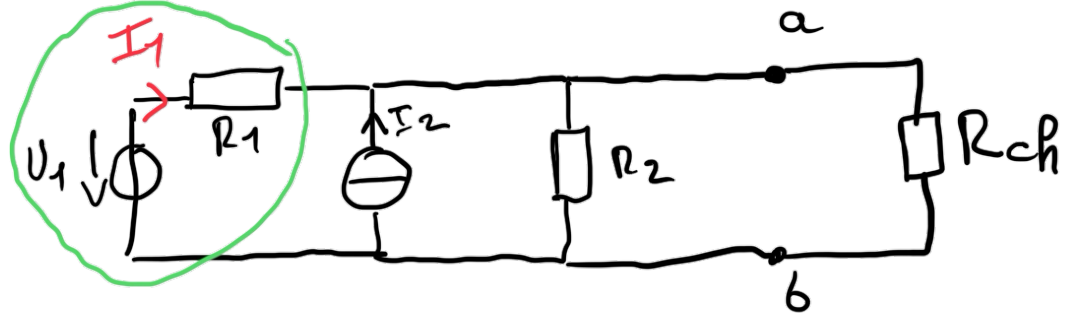

$$U_0 = R_{12} \left(\frac{U_1}{R_1} + I_2 \right)$$

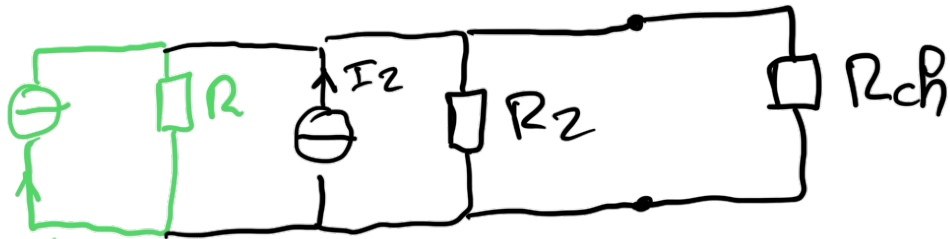

$$I_{cc} = \frac{U_1}{R_1}$$

$$R_{12} = \frac{R_1 R_2}{R_1 + R_2}$$

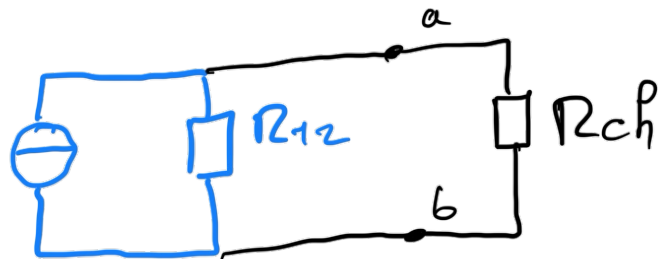

5.8 PRINCIPE DE SUPERPOSITION

Électrotechnique I

Yves PERRIARD & Yoan CIVET

Laboratoire d'Actionneurs Intégrés

Excitation d'un circuit et réponse du circuit à une excitation

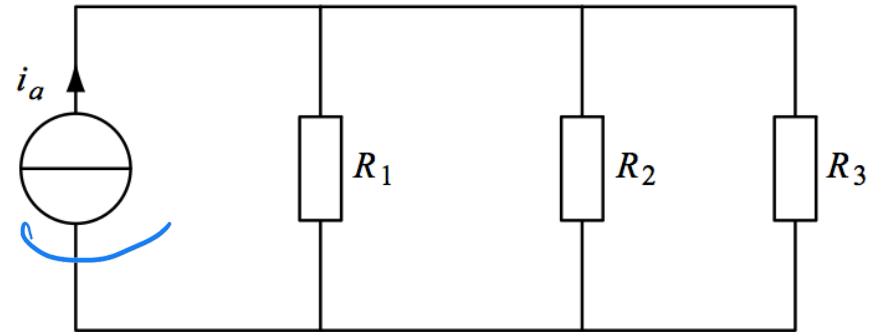
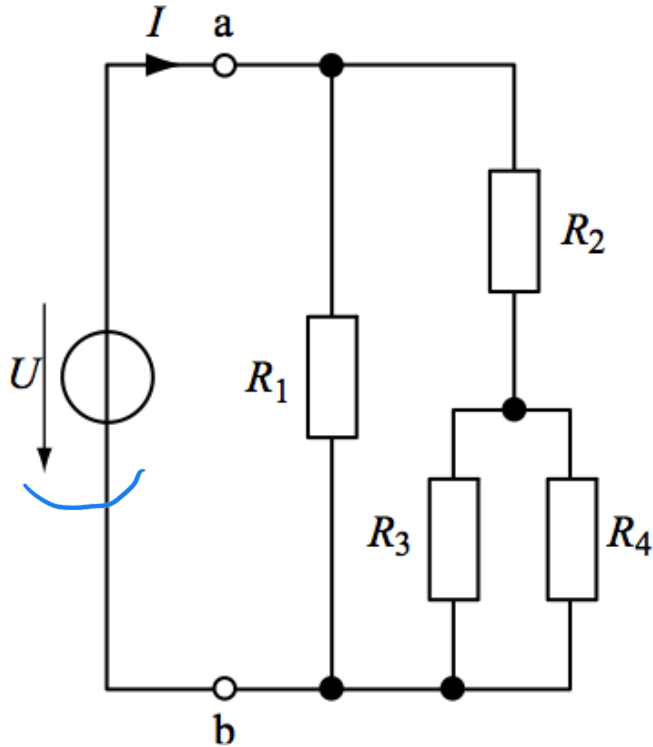

Énoncé

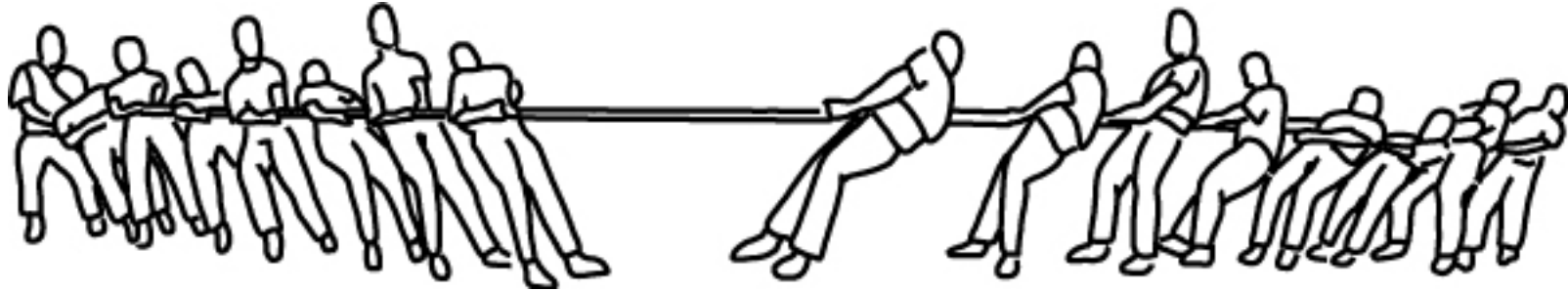

Énoncé

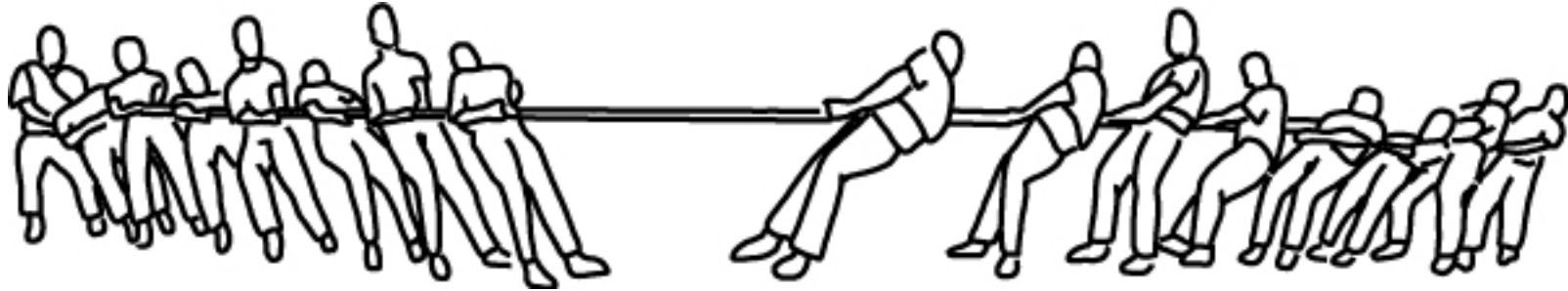

La réponse du système à une somme d'excitations
est égale à
la somme des réponses dues à chaque excitation prise séparément.

Énoncé

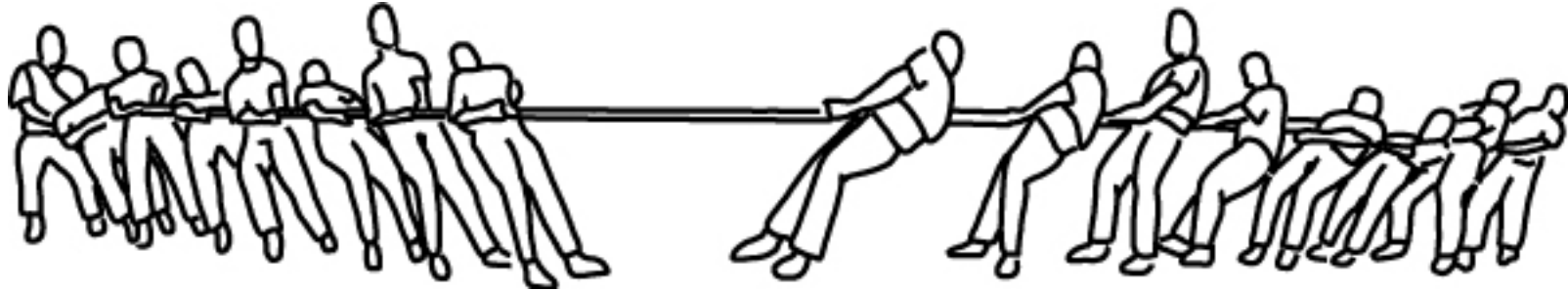

La réponse du système à une somme d'excitations
est égale à
la somme des réponses dues à chaque excitation prise séparément.

Le système doit être linéaire !!

Méthodologie

- Eviter une méthode d'analyse globale souvent lourde
- → Succession de calculs partiels
- A chaque étape, une seule source est prise en compte
- Les autres sont annulées
- Le résultat total est la somme algébrique des résultats partiels

Que signifie « annuler une source » ?

* Source de tension

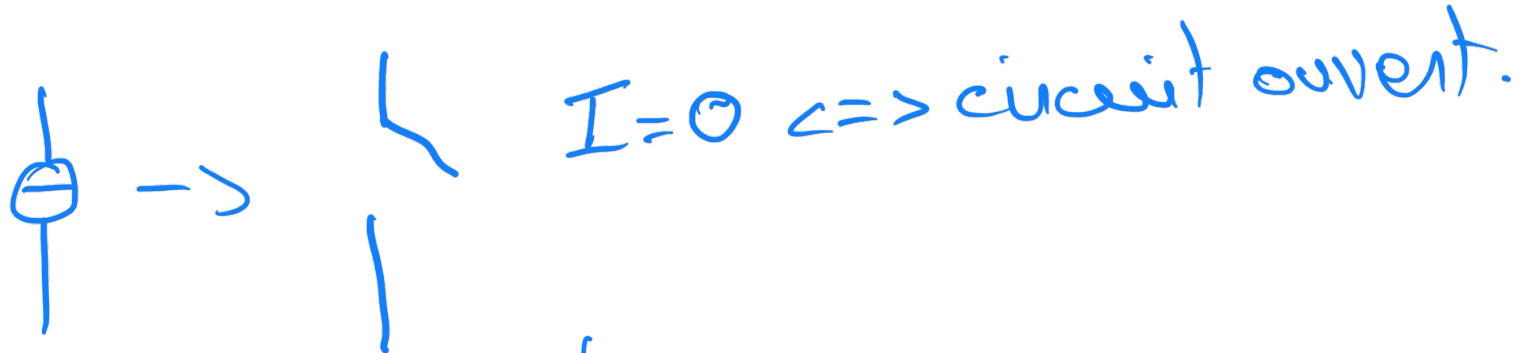
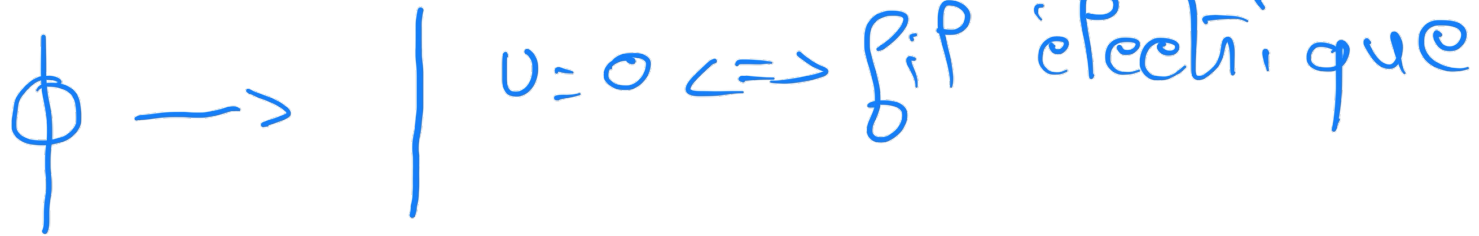

* Source de courant.

Exemple

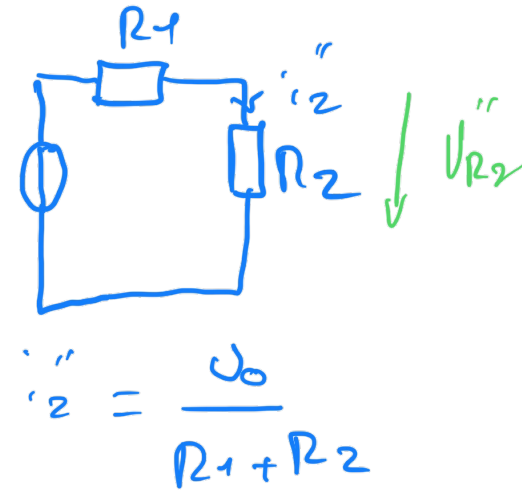
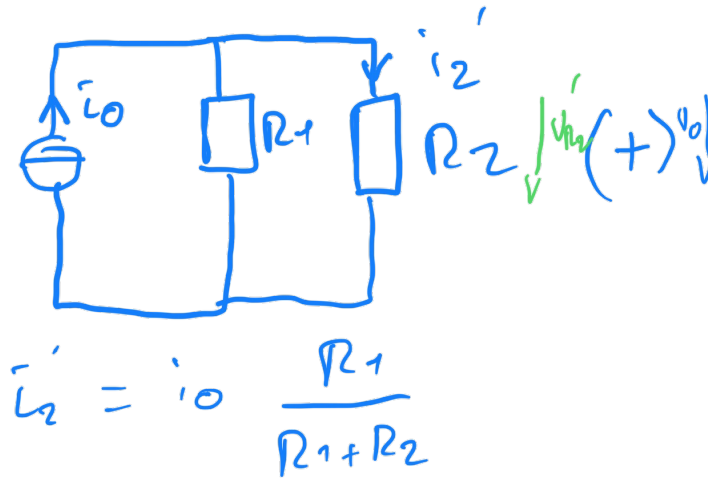
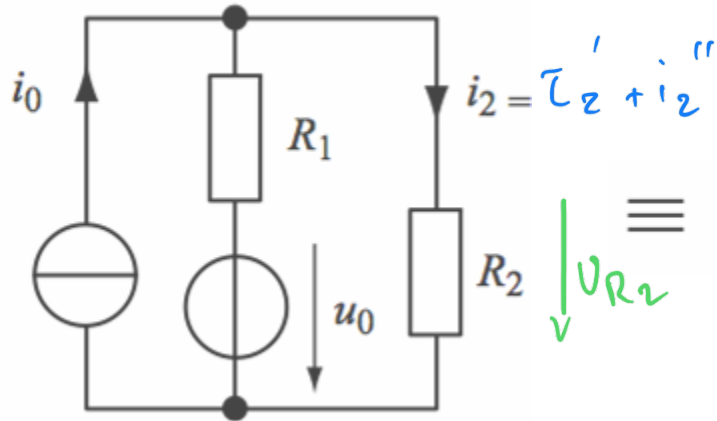

$$\Rightarrow \underline{i_2 = i_2' + i_2''}$$

$$\underline{U_{R_2} = U_{R_2}' + U_{R_2}''}$$

- Circuit complexe
- → somme de circuits plus simples
- Les éléments doivent être linéaires
- Prêter attention aux signes

5.9 TRANSFORMATION Π -T

Électrotechnique I

Yves PERRIARD & Yoan CIVET

Laboratoire d'Actionneurs Intégrés

Introduction

- Circuits particuliers
- Trois éléments (tripôle) connectés
 - « en π », « en triangle » ou « en Δ »
 - « en T », « en étoile » ou « en Y »
- Equivalence

Exemples de circuits difficiles à simplifier

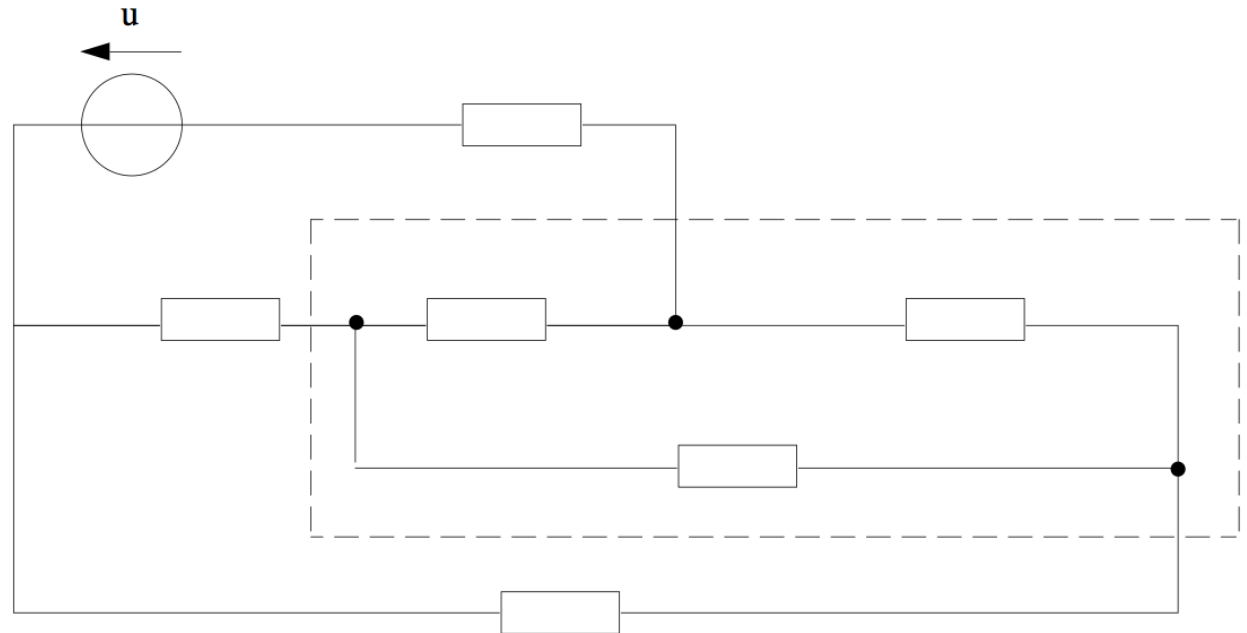
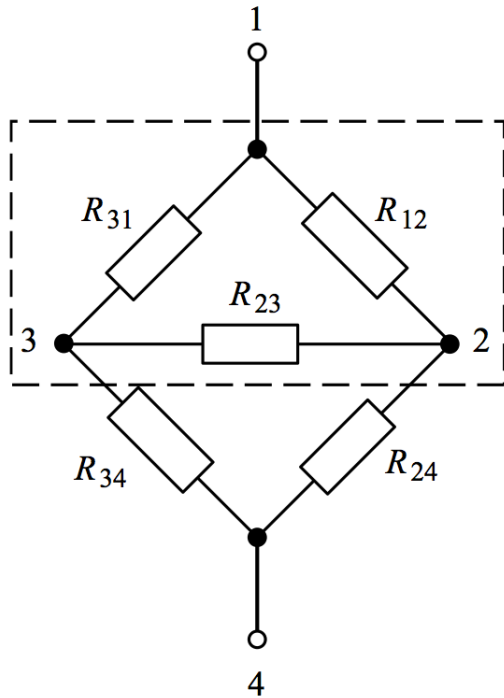

Tripôles « en π » (ou « en triangle », « en Δ » ou « *Delta connection* »)

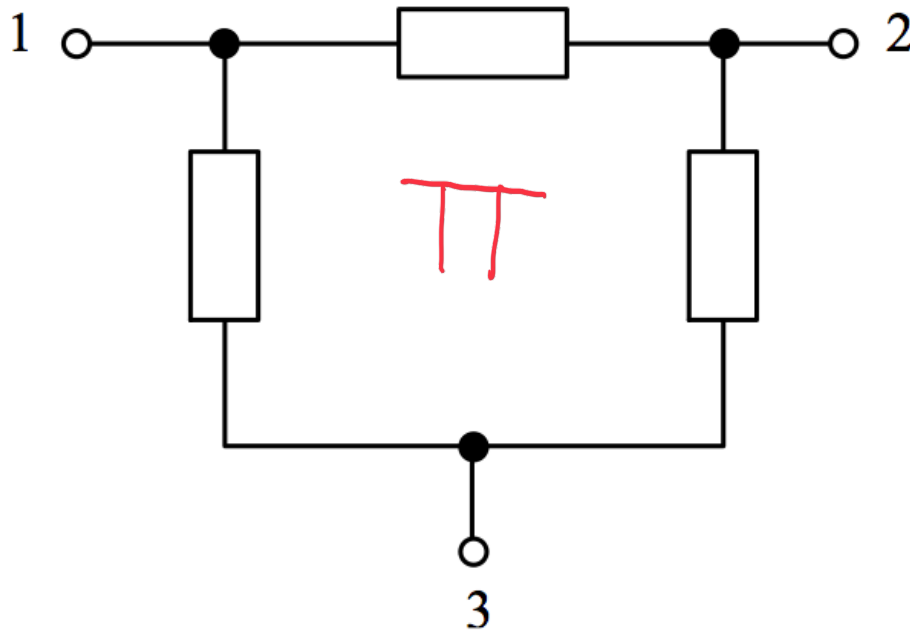

≡

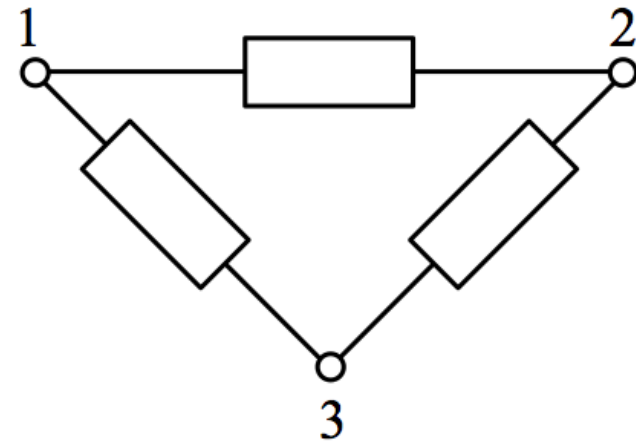

Tripôles « en T » (ou « en étoile », « en Y » ou « *Star connection* »)

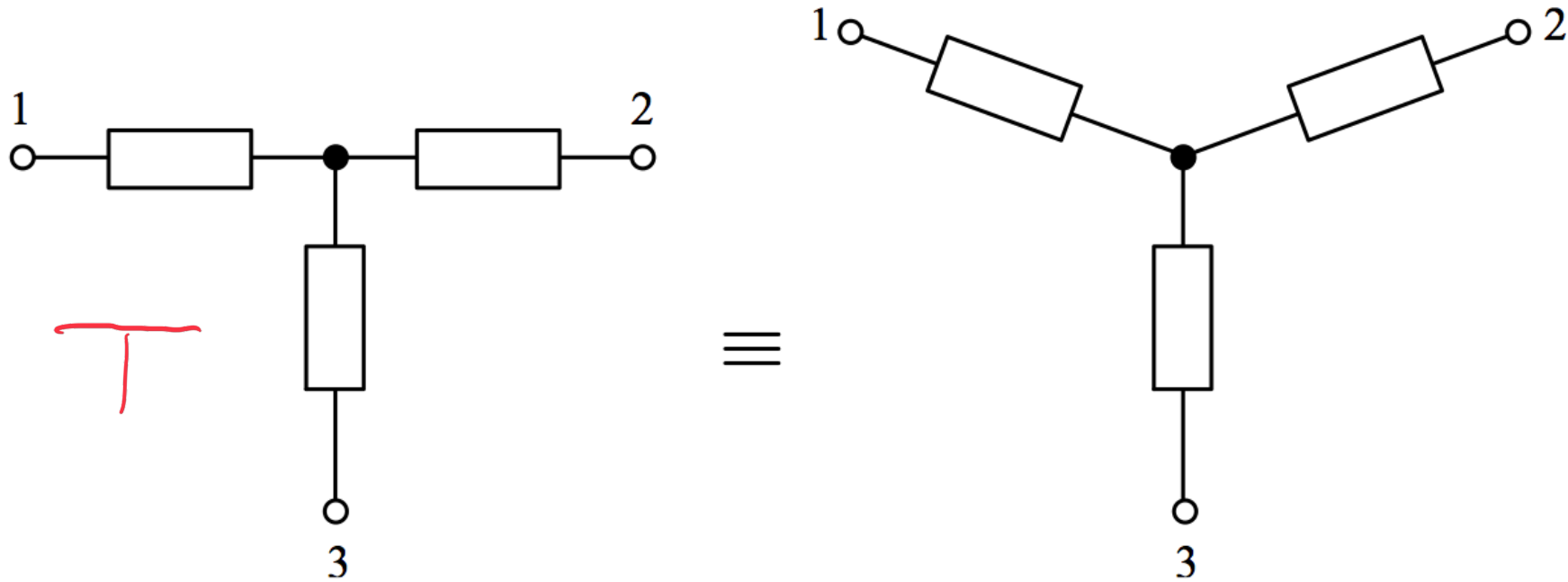

Équivalence de tripôles « en T » et « en π »

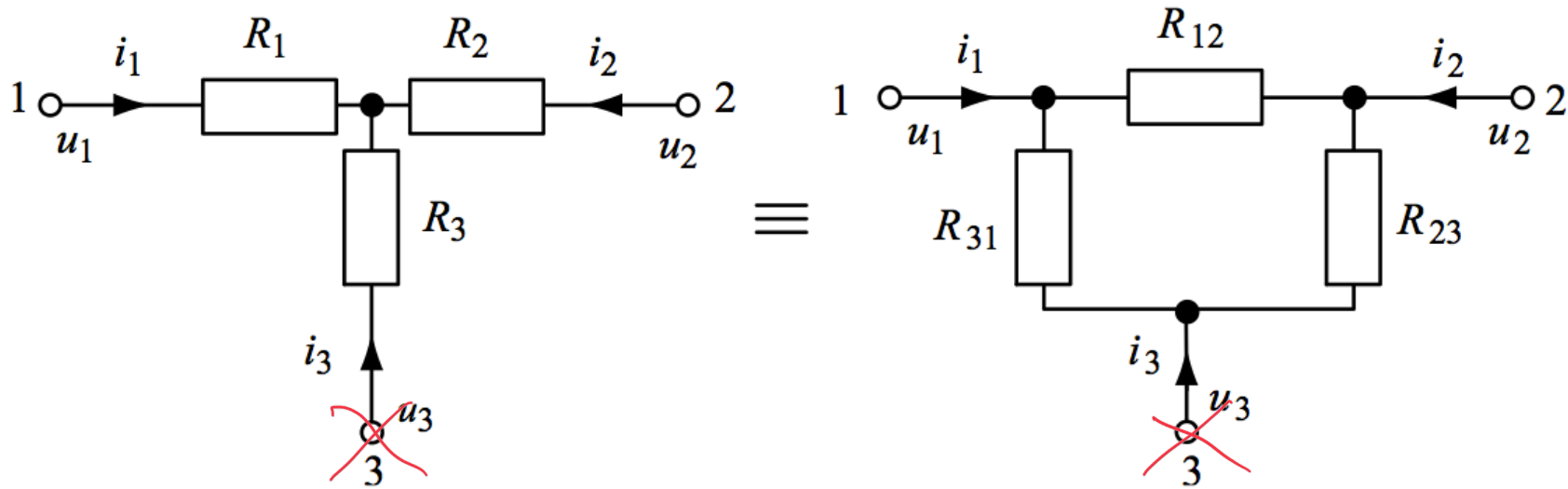

Équivalence de tripôles « en T » et « en π »

Si on annule la borne 3

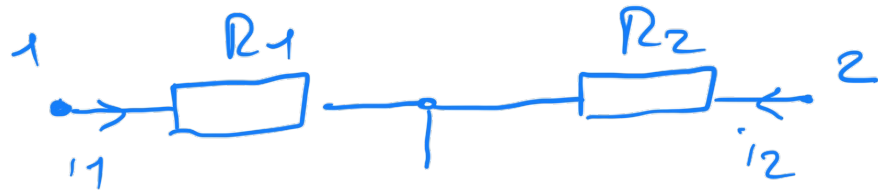

$$R_{eq1} = R_1 + R_2$$

$$\Rightarrow R_1 + R_2 = \frac{R_{12}(R_{31} + R_{23})}{R_{12} + R_{23} + R_{31}}$$

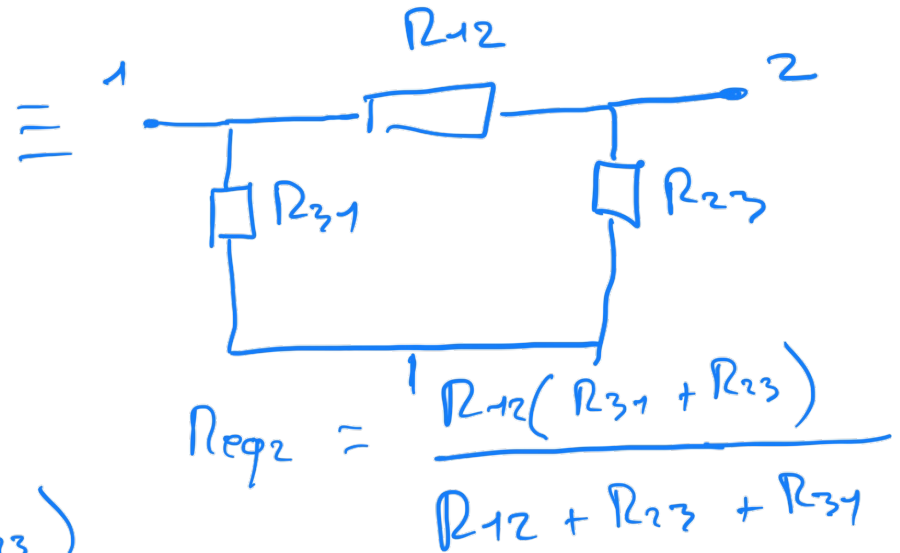

$$R_{eq2} = \frac{R_{12}(R_{31} + R_{23})}{R_{12} + R_{23} + R_{31}}$$

TRANSFORMATION Π-T

$$R_1 + R_2 = \frac{R_{12}(R_{23} + R_{31})}{R_{12} + R_{23} + R_{31}} \quad (1)$$

$$R_2 + R_3 = \frac{R_{23}(R_{12} + R_{31})}{R_{12} + R_{23} + R_{31}} \quad (2)$$

$$R_3 + R_1 = \frac{R_{31}(R_{12} + R_{23})}{R_{12} + R_{23} + R_{31}} \quad (3)$$

$$\frac{1}{2} [(1) - (2) + (3)]$$

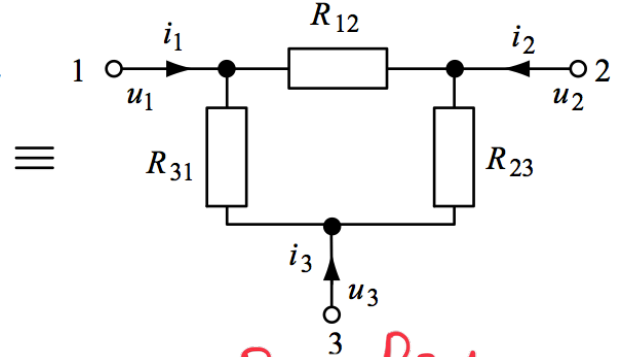
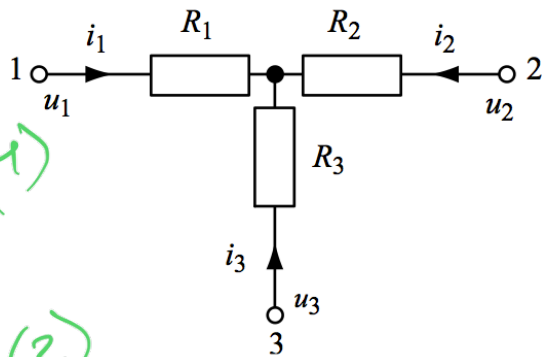

$$R_1 = \frac{R_{12} R_{31}}{R_{12} + R_{23} + R_{31}}$$

$$R_2 = \frac{R_{12} R_{23}}{R_{12} + R_{23} + R_{31}}$$

$$R_3 = \frac{R_{23} R_{31}}{R_{12} + R_{23} + R_{31}}$$

Équivalence de tripôles « en T » et « en π » - Opération inverse

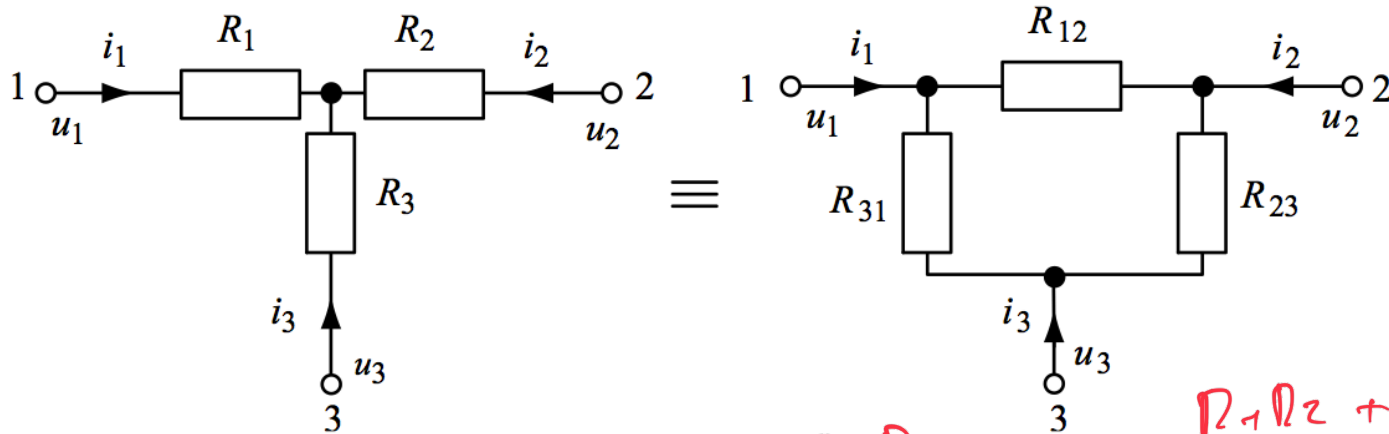

$$R_{12} = R_1 + R_2 + \frac{R_1 R_2}{R_3}$$

$$R_{23} = R_2 + R_3 + \frac{R_2 R_3}{R_1}$$

$$R_{31} = R_3 + R_1 + \frac{R_3 R_1}{R_2}$$

$$= \frac{R_1 R_2 + R_1 R_3 + R_2 R_3}{R_3}$$

Exemple

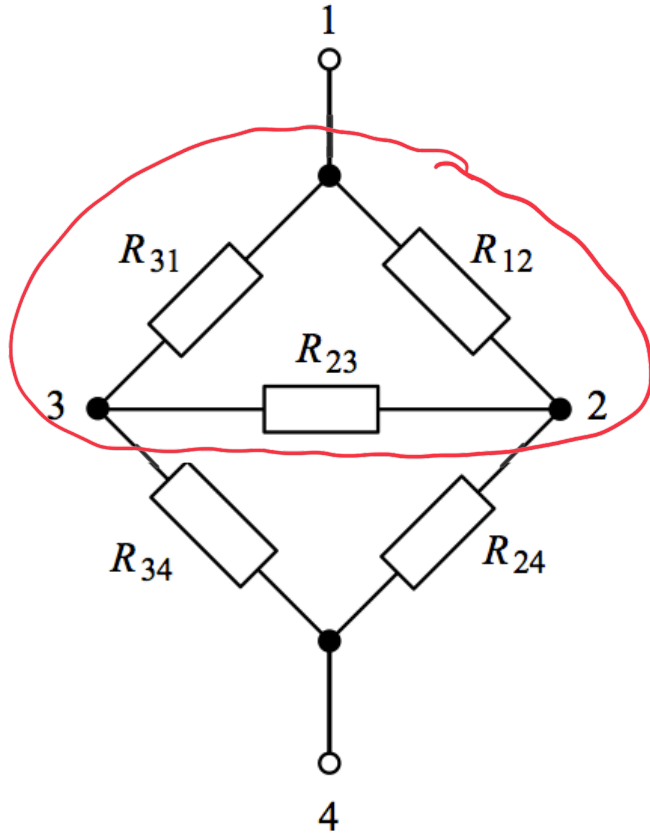

Exemple

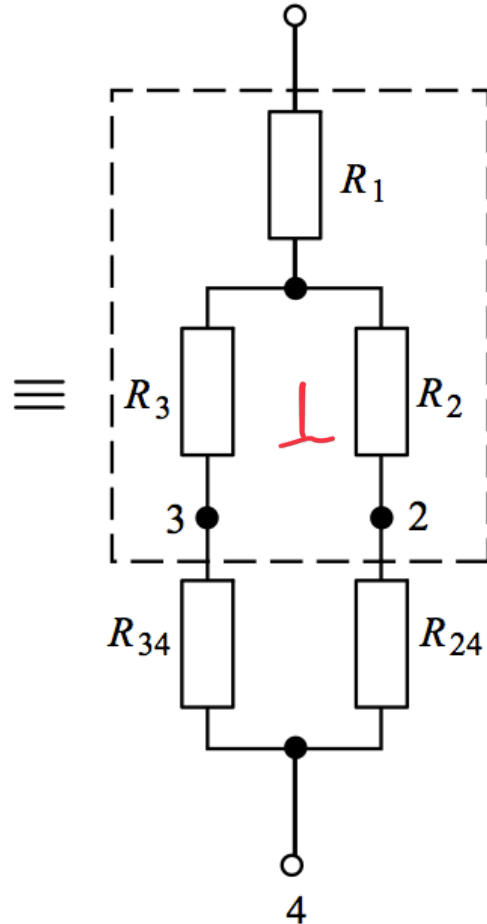
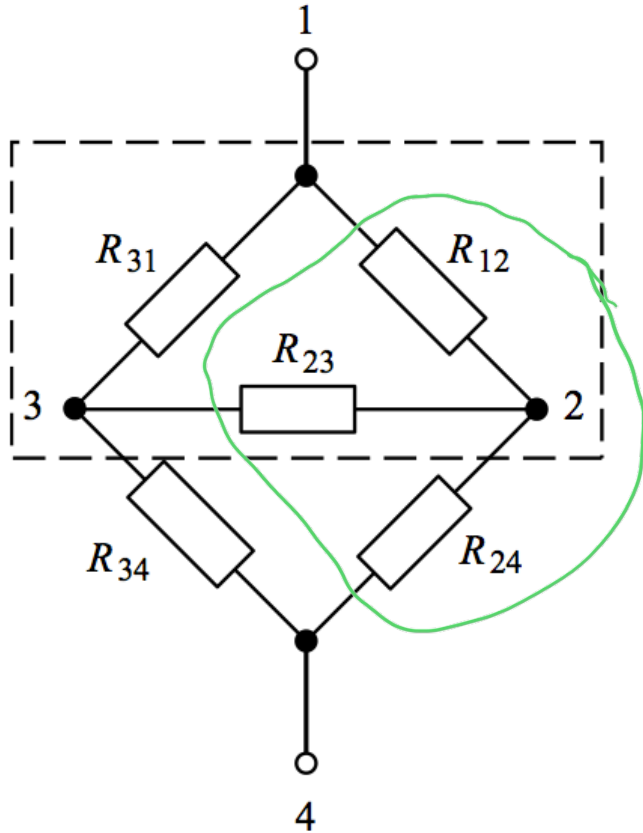

$$R = R_1 + \frac{(R_2 + R_{24})(R_3 + R_{34})}{R_2 + R_{24} + R_3 + R_{34}}$$

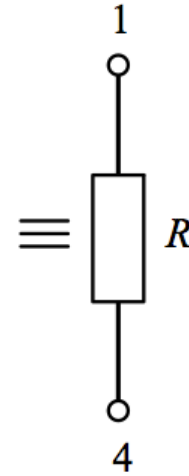

Exemple

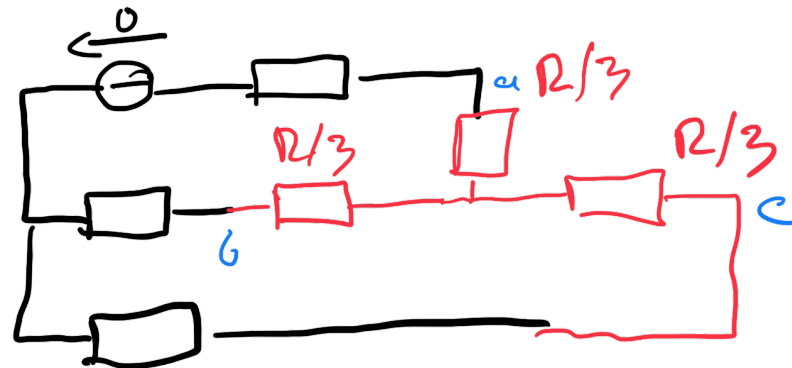
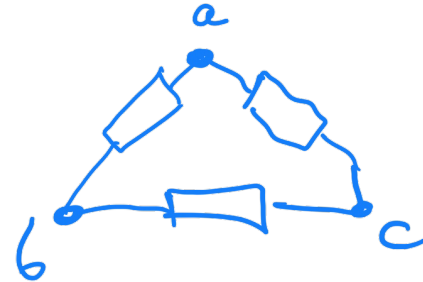
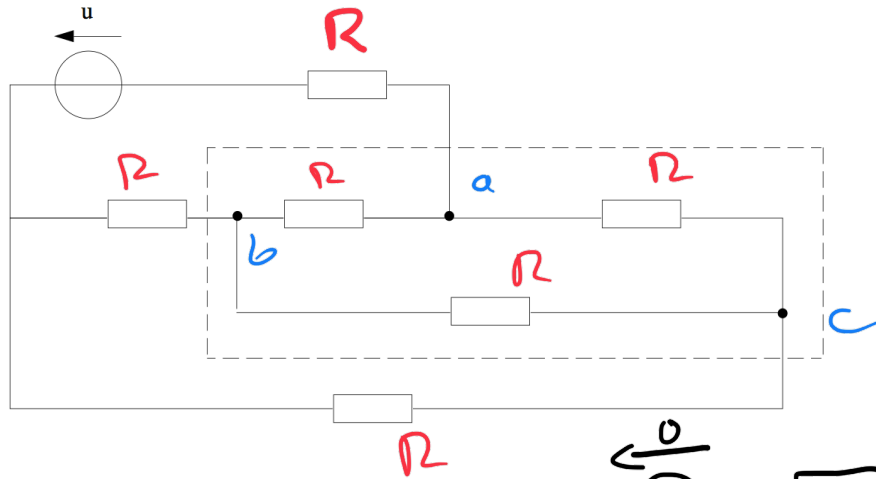

5.11 PUISSANCE MAXIMALE ET ADAPTATION

Électrotechnique I

Yves PERRIARD & Yoan CIVET

Laboratoire d'Actionneurs Intégrés

Source de tension réelle – Charge – Puissance

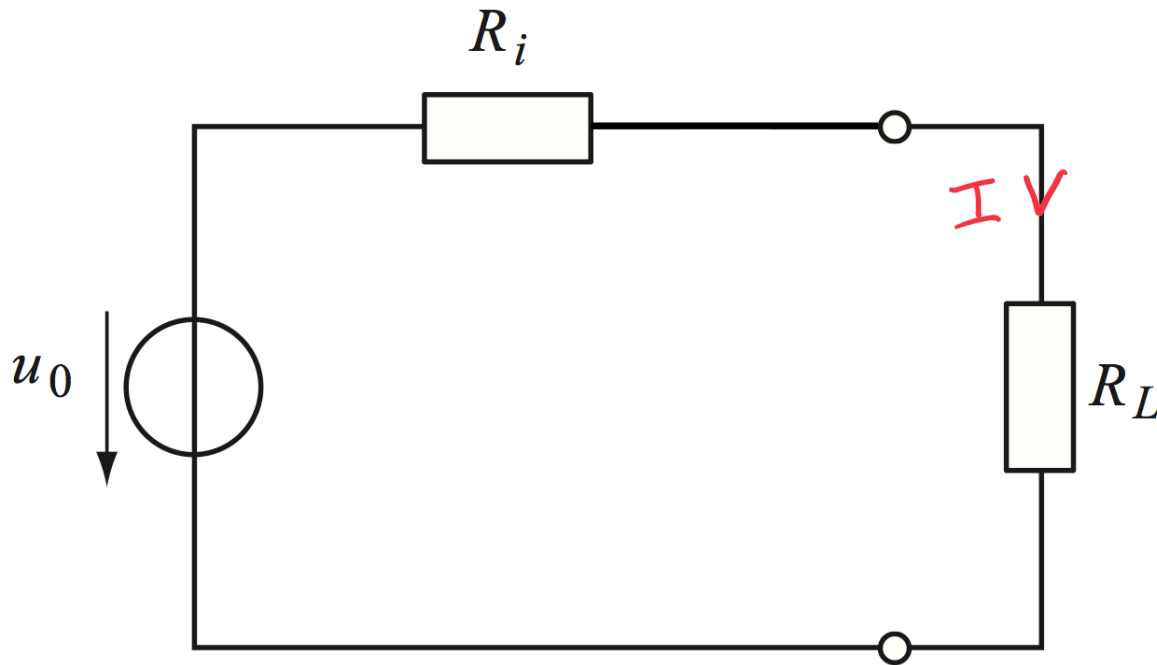

$$P_{RL} = U_{RL} I = R_L I^2$$

$$\text{ou } I = \frac{U_0}{R_L + R_i}$$

$$\Rightarrow P_{RL} = \frac{R_L U_0^2}{(R_i + R_L)^2}$$

R_L ?

pour que P_{RL} soit max.

Puissance maximale

$$\frac{dP_{RL}}{dR_L}$$

$$P_{RL} = \frac{P}{g}$$

$$\frac{dP_{RL}}{dR_L} = \frac{b'g - g'b}{g^2}$$

$$\frac{dP_{RL}}{dR_L} = \frac{U_0^2 (R_L + R_i)^2 - 2U_0^2 R_L (R_L + R_i)}{(R_L + R_i)^4} = 0$$

$$\Rightarrow R_i^2 = R_L^2$$

$$\Rightarrow R_i = R_L$$

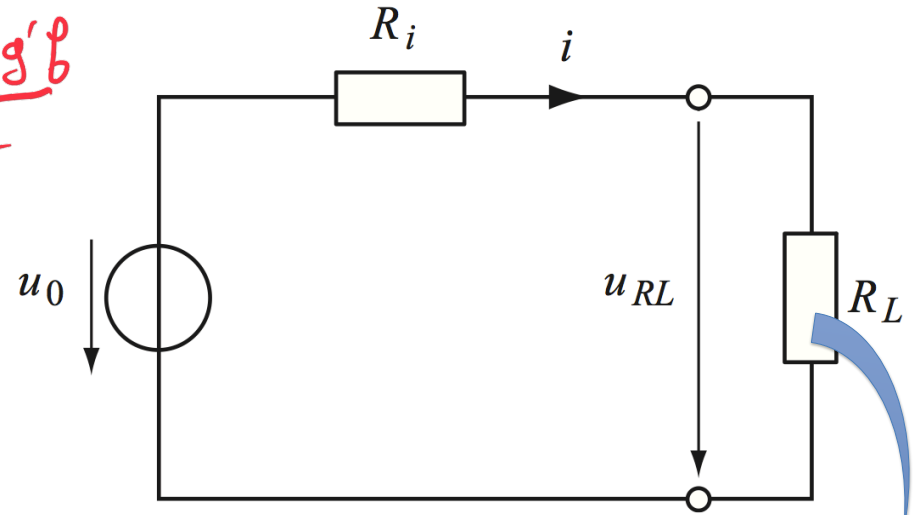
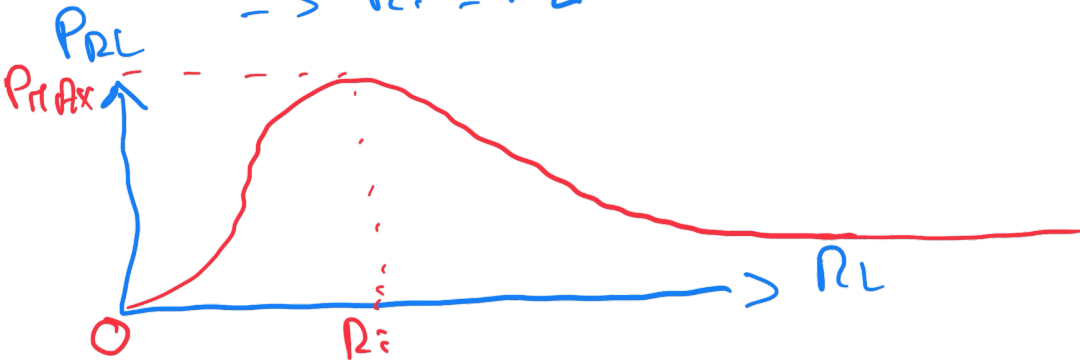

$$P_{RL} = \frac{u_0^2 R_L}{(R_L + R_i)^2}$$

Puissance maximale

Condition : $R_L = R_i$

La condition d'adaptation de puissance est donc réalisée lorsque la valeur de la résistance de charge et celle de la résistance interne de la source sont égales.

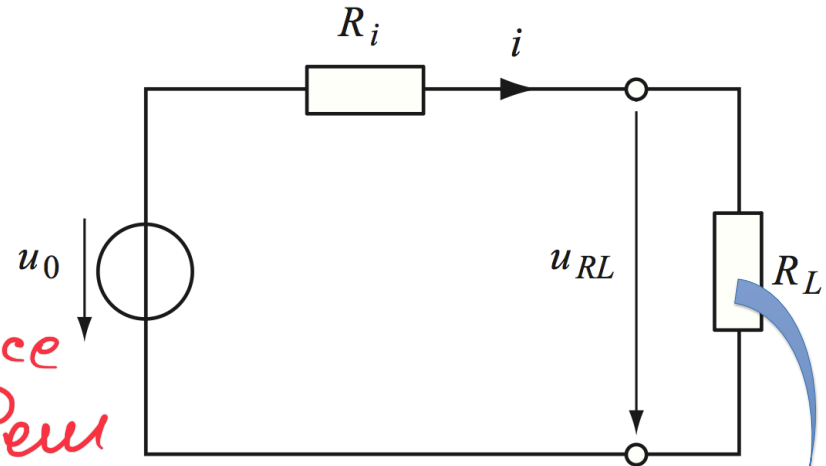

$$P_{RL} = \frac{u_0^2 R_L}{(R_L + R_i)^2}$$

Rendement

$$\eta = \frac{P_{\text{utile}}}{P_{\text{consommée}}} = \frac{R_L I^2}{(R_L + R_i) I^2}$$

$$\text{Si } R_L = R_i$$

$$\eta = 0,5$$

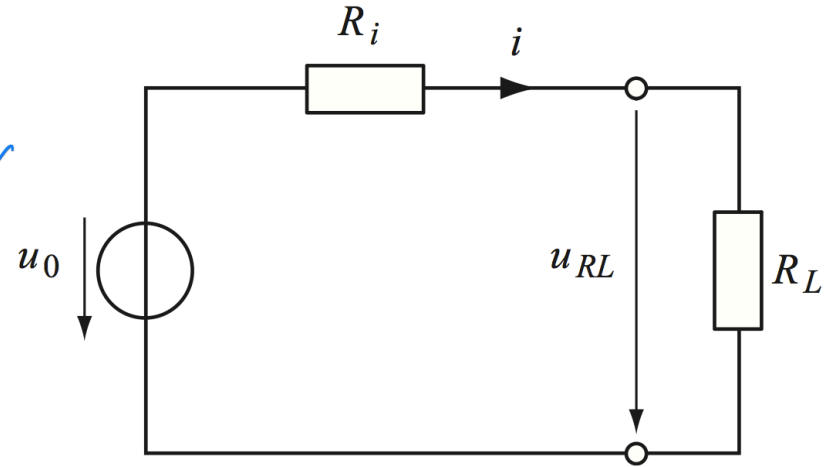

Simulation sous Falstad

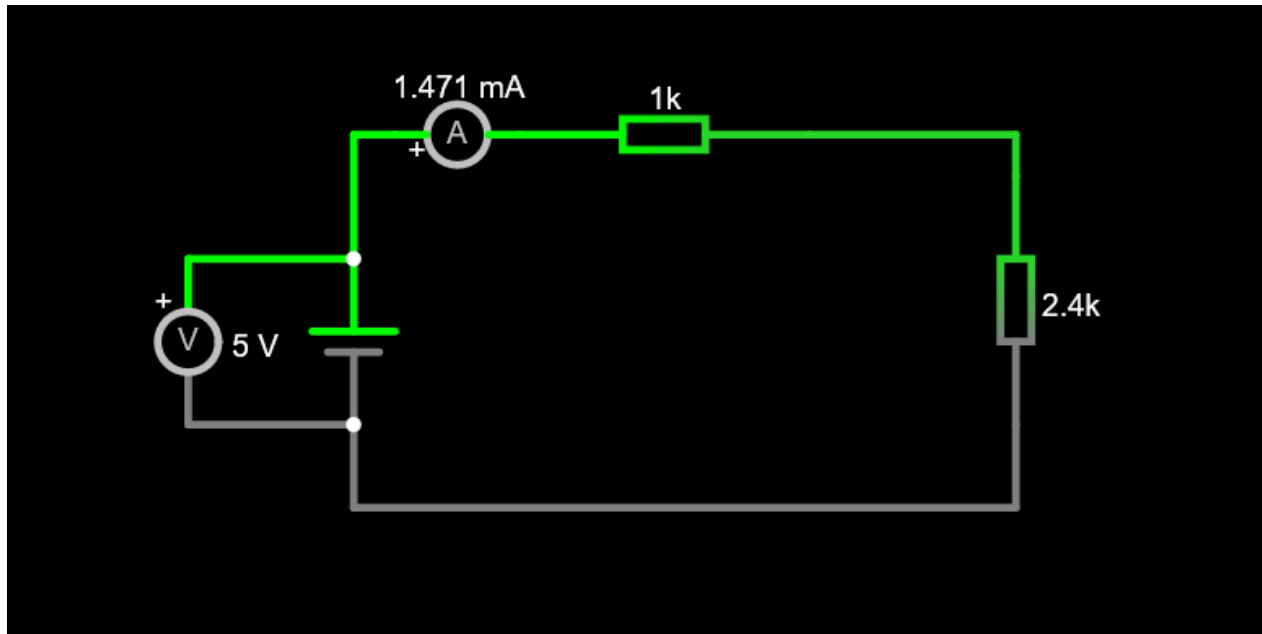

<https://www.falstad.com/circuit/>

6. Régime Sinusoïdal Nonphasé

6.2 Grandeurs Sinusoïdales :

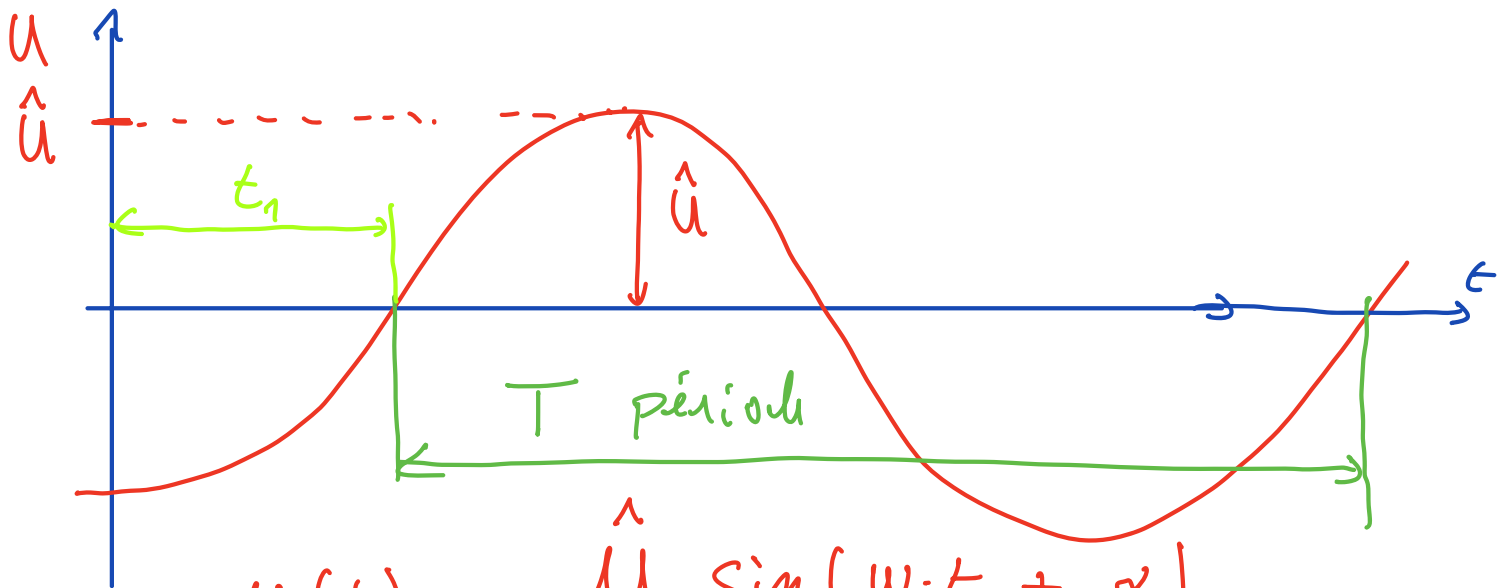

$$u(t) = \hat{u} \sin(\omega \cdot t + \alpha)$$

T = période du signal (s)

$$f = \text{fréquence} = \frac{1}{T}$$

$$\omega = \text{pulsation} = \frac{2\pi}{T} = 2\pi f$$

$$\alpha = \frac{t_1 \cdot 2\pi}{T}$$

Continu

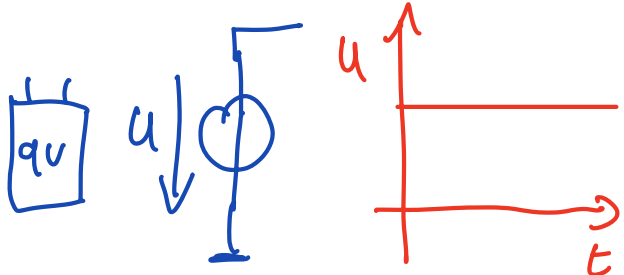

Sinus

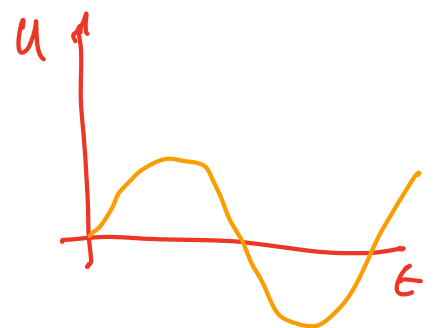

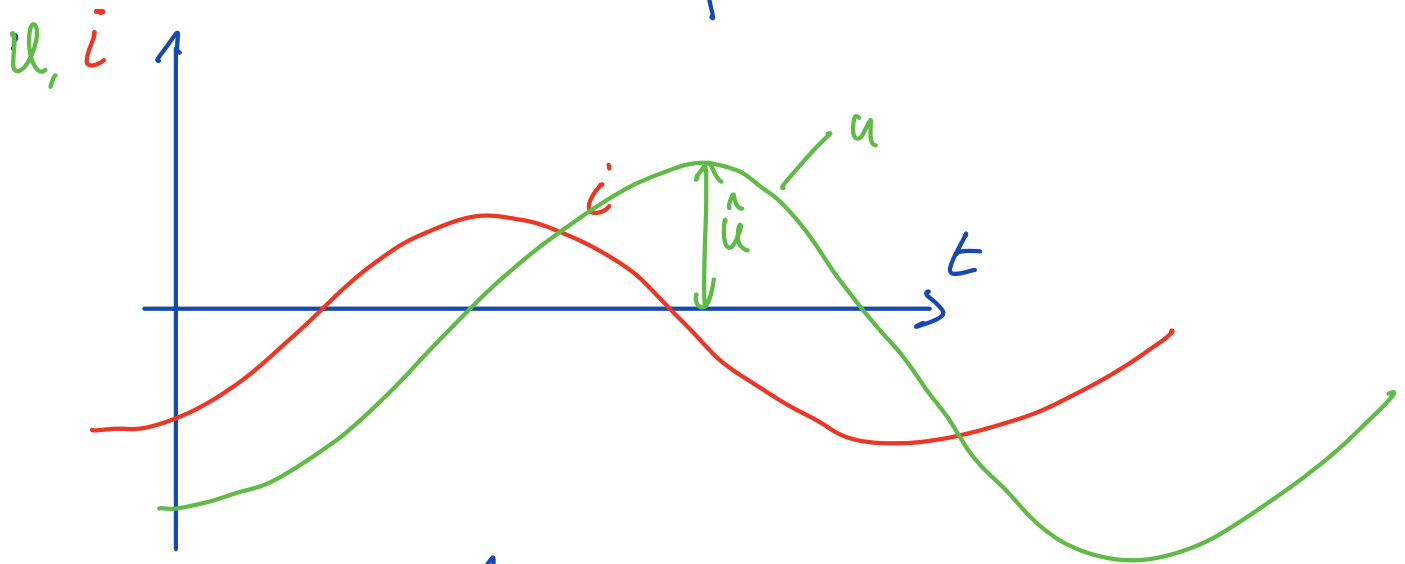

$$u(t) = \hat{u} \sin(\omega t + \alpha) = u$$

$$i(t) = \hat{i} \sin(\omega t + \beta) = i$$

Définition : $\varphi = \alpha - \beta$ (Déphasage entre u et i)

Définition de la valeur moyenne :

$$\bar{x} = \frac{1}{T} \int_0^T x(t) dt$$

↑
Moyenne

$$\bar{u} = \frac{1}{T} \int_0^T \hat{u} \sin(\omega t + \alpha) dt = 0$$

Поиск среднего $u(t)$, $\text{sur } T/2$:

$$\bar{u} \Big|_{T/2} = \frac{1}{T/2} \int_0^{T/2} \hat{u} \sin(\omega t) dt$$

On pose $a=0$

$$= \frac{2 \hat{u}}{T} \frac{1}{\omega} \left[-\cos\left(\frac{T}{2} \cdot \omega\right) + \cos(0) \right]$$

$$\omega = \frac{2\pi}{T}$$

$$= \frac{\cancel{2} \hat{u} \cancel{T}}{\cancel{T} \cdot \cancel{2\pi}} \left[-\cos\left(\frac{\cancel{T}}{2} \cdot \frac{\cancel{2\pi}}{\cancel{T}}\right) + \cos(0) \right]$$

$$= \frac{\hat{u}}{\pi} [1 + 1] = \frac{2}{\pi} \cdot \hat{u}$$

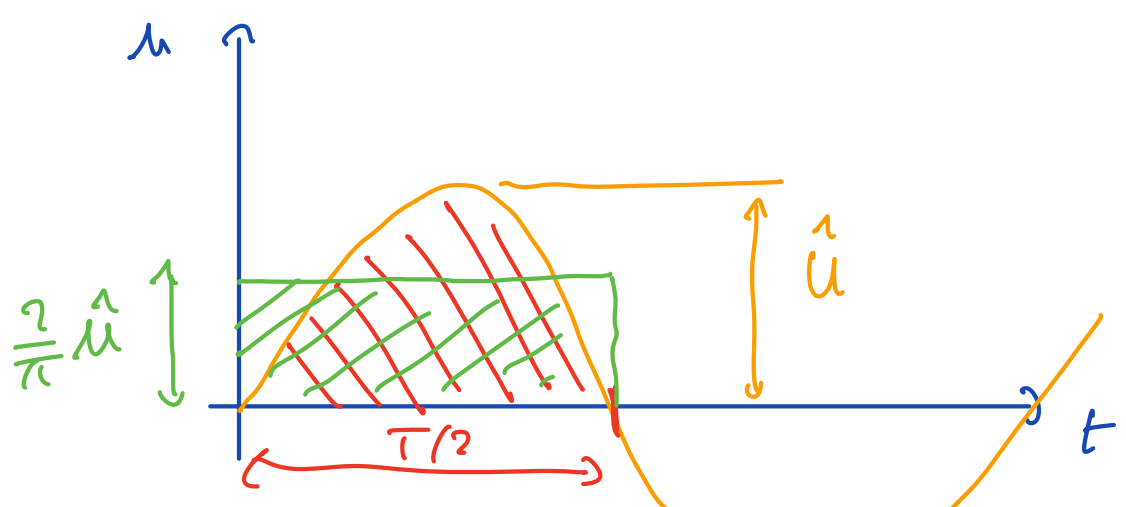

6.2.13 Puissance instantanée

$$p = u \cdot i \quad (\text{en fonction du temps})$$

Calcul de la puissance dissipée dans une

Résistance :

$$p = R \cdot i^2 = \frac{u^2}{R}$$

$$p = \frac{u^2}{R} = \frac{u^2 \sin^2(\omega t + \alpha)}{R}$$

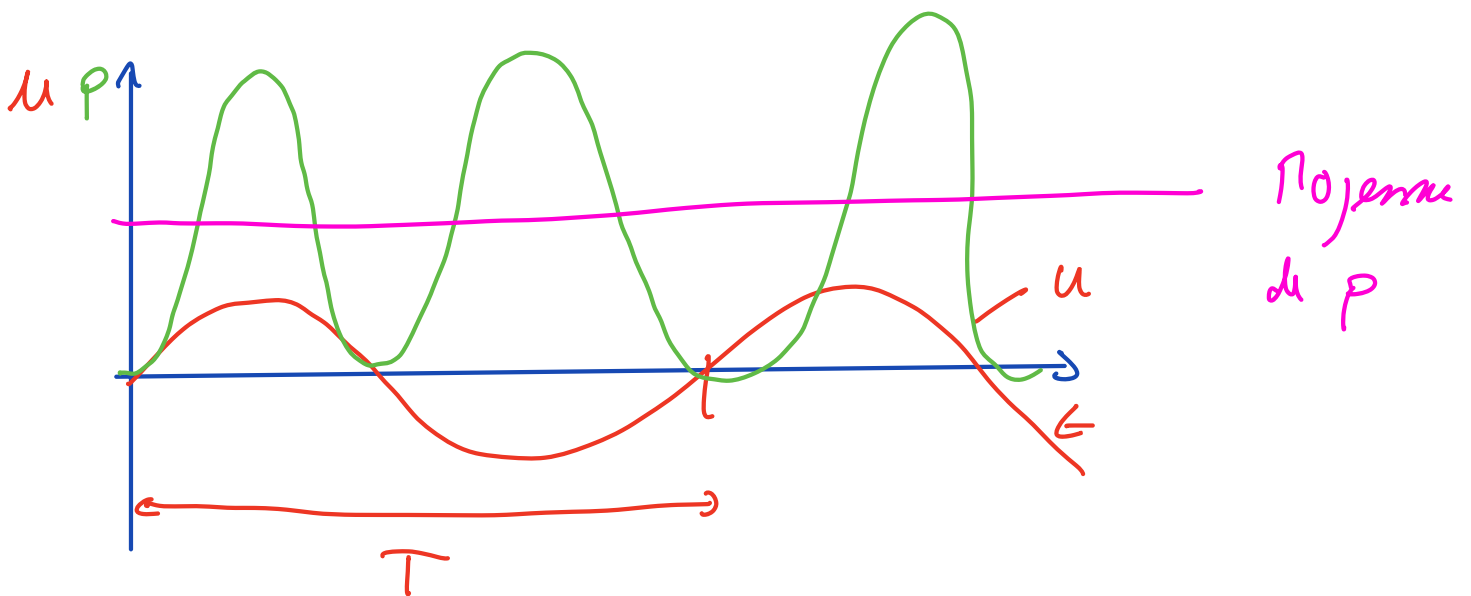

T

$$\overline{P}_R = \frac{1}{T} \int_0^T \frac{\hat{u}^2}{R} \sin^2(\omega t + \alpha) dt$$

$$\overline{P}_R = \frac{1}{T} \int_0^T \frac{\hat{u}^2}{R} \cos^2(\omega t + \alpha) dt$$

+

$$2 \overline{P}_R = \frac{1}{T} \int_0^T \frac{\hat{u}^2}{R} \cdot 1 dt$$

$$2 \overline{P}_R = \frac{\hat{u}^2}{R}$$

$$\underline{\underline{\overline{P}_R = \frac{\hat{u}^2}{2R}}}$$

En continu : $P_R = \overline{P}_R = \frac{u^2}{R}$

6.2.12 Définition de la valeur efficace
(RMS Root Mean Square)

$$u = \sqrt{\frac{1}{T} \int_0^T \hat{u}^2 \sin^2(\omega t + \alpha) dt}$$

Полезные

$$\sin^2 x = \frac{1 - \cos 2x}{2}$$

$$U = \frac{\hat{U}}{\sqrt{2}} \quad (\text{эффект})$$

$$\hat{U} = U \cdot \sqrt{2}$$

↑
Crête

↑
эффект

$$\bar{P}_R = \frac{\hat{U}^2}{2R} = \frac{U^2}{R} = P_{R \text{ en DC}}$$

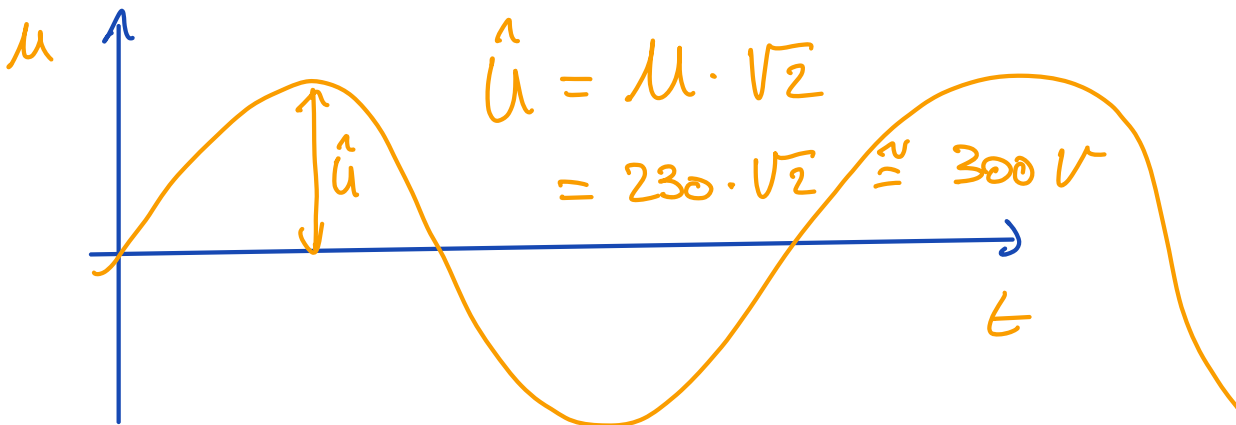

u, i : Valeurs instantanées

U, I : " efficaces

\hat{U}, \hat{I} : " crêtes

\bar{u}, \bar{i} : " moyennes

6.2.14 cas de R :

$$u = R \cdot i$$

$$\hat{u} \cos(\omega t + \alpha) = R \cdot \hat{I} \cos(\omega t + \beta)$$

$$\text{Donc } \hat{u} = R \cdot \hat{I}$$

$$\alpha = \beta$$

u est en phase
avec i

6.2.15 cas de L

$$u = L \frac{di}{dt}$$

$$\hat{u} \cos(\omega t + \alpha) = -\omega L \hat{I} \sin(\omega t + \beta)$$

$$= +\omega L \hat{I} \cos\left(\omega t + \beta + \frac{\pi}{2}\right)$$

$$\hat{u} = \omega L \hat{I}$$

$$\alpha = \beta + \frac{\pi}{2}$$

Tension et le courant
sont en quadrature
: retard du courant

de $\frac{\pi}{2}$ sur la tension

6.2.16 cas de C

$$i = C \frac{du}{dt}$$

$$\begin{aligned} \hat{I} \cos(\omega t + \beta) &= -\omega C \hat{U} \sin(\omega t + \alpha) \\ &= \omega C \hat{U} \cos\left(\omega t + \alpha + \frac{\pi}{2}\right) \end{aligned}$$

$$\hat{U} = \frac{\hat{I}}{\omega C}$$

$$\alpha = \beta - \frac{\pi}{2}$$

Tension et courant sont
en quadrature

: avance du courant de $\frac{\pi}{2}$
sur la tension

6.3 Calcul complexe associé :

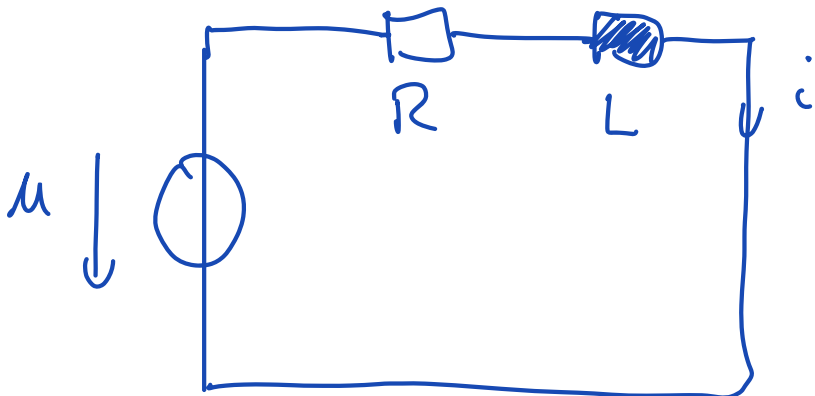

$$u = \hat{U} \sin(\omega t + \alpha) \quad \text{comme}$$

$$i = \hat{I} \sin(\omega t + \beta) \text{ inconnue ?}$$

comme l'origine du temps est arbitraire :

$$\text{on pose } \alpha = 0$$

$$u = R \cdot i + L \frac{di}{dt}$$

$$\hat{u} \sin(\omega t) = R \hat{I} \sin(\omega t + \beta) + L \omega \hat{I} \cos(\omega t + \beta)$$

Autre méthode :

$$\text{nb complexe : } j = \sqrt{-1}$$

Rappel :

$$\underline{X} = a + bj$$

↑
vecteur

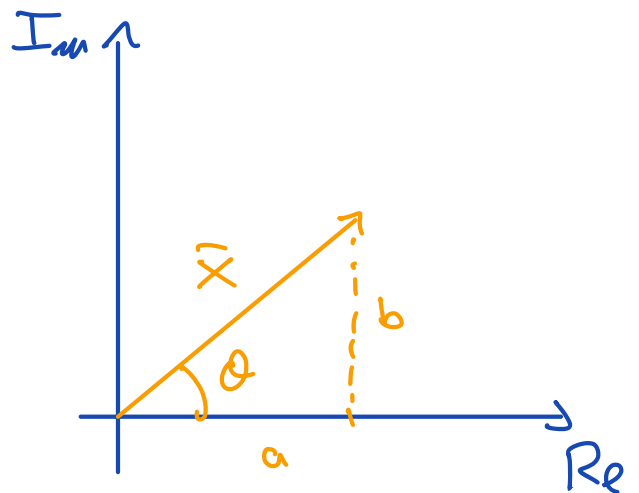

$$\underline{X} = \hat{X} (\cos(\theta) + j \sin(\theta))$$

$$\underline{X} = \hat{X} e^{j\theta}$$

Formule
d'Euler

Concept :

$$u = \hat{u} \sin(\omega t) \xrightarrow{\text{trans. complex}} \underline{u} = \hat{u} e^{j(\omega t)}$$

⋮
calcul

$$u = \text{Im} \{ \underline{u} \}$$



$$i = \hat{I} \sin(\omega t + \beta) \xrightarrow{\quad}$$

$$\underline{i} = \hat{I} e^{j(\omega t + \beta)}$$

$$\underline{i} = \text{Im} \{ \underline{i} \}$$

